

2106-12-12 Fish Hoek End-of-year Class

1 DAN: THE DANCING RHINO R32 · 2RR

Heather Hodgson · Diagram: Keith Rose's Diagrams

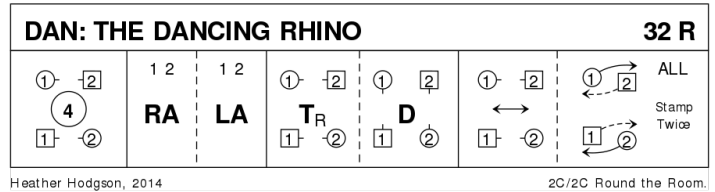

2 PELORUS JACK J32 · 3/4L

Barry Skelton: RSCDS XLI 1 · Crib: Eric Ferguson's SCD Cribbs · Diagram: Keith Rose's Diagrams

- 1- 1c cross RH, cast (2c up) ; 1c+3c RHA, finish 1M facing 1cnr, 1W behind him
- 9- 1c in tandem +1cnrs ½ diagonal Reel3, Rsh to 3W (1M & 1W loop R singly for lead change, so 1W now leads P) ; ½ diagonal Reel3, Rsh to 2W (+ lead change)
- 17- Continue pattern twice
- 25- 2c+1c LHA ; 1c turn LH ½ | all set (2,1,3)

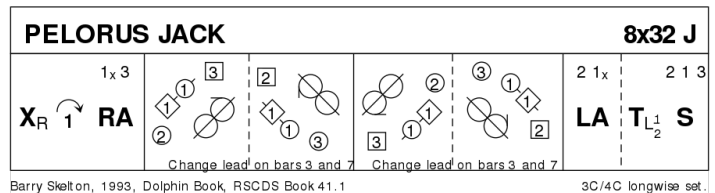

3 THE BYRON STRATHSPEY S32 · 3/3L

John Drewry: Deeside Book Part 2 · Crib: Eric Ferguson's SCD Cribbs · Diagram: Keith Rose's Diagrams

- 1- 1c+2c+3c Petronella Turn into midline, set ; all turn P BH 1¼ to (1,2,3)
- 9- "Teapots": 1c+2W & 2M+3c RHA ; 1c+2M & 2W+3c LHA , to (1,2,3) with 1c facing out and 2c facing up in promhold
- 17- 2c (promhold) +1W+1M Reel3 across (Rsh to 1W), at end all dance in for
- 25- 2c+1c+3c Allemande (to 3,1,2).

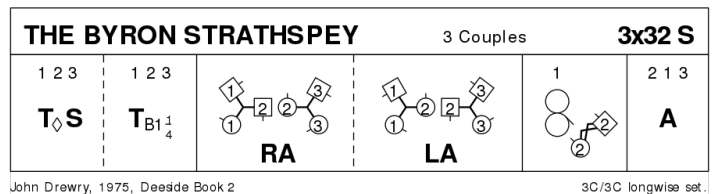

4 CITY OF STIRLING REEL R32 · 3/4L

Roy Goldring: Bannockburn 700 · Crib: Eric Ferguson's SCD Cribbs · Diagram: Keith Rose's Diagrams

- 1- 1c+2c Snowball G-Chain (4 hands of 2 bars), to start 1c+2c change place RH on the side (3x,1x,2x) (1W no polite turn at the end)
- 9- 1c cross Rsh | Turn 3cncr pos. RH ½ ; with cncr following pass Lsh on the diagonal and curve into 2plx, the cncrs returning to own 1cncr positions
- 17- 1c cross Lsh | Turn 4cncr pos. LH ½ ; with cncr following pass Rsh on the diagonal and curve into 2plx, the cncrs returning to own 2cncr positions (2,1x,3)
- 25- All turn P RH ; 1c ½ Fig8 L (W up, M dn) (2,1,3)

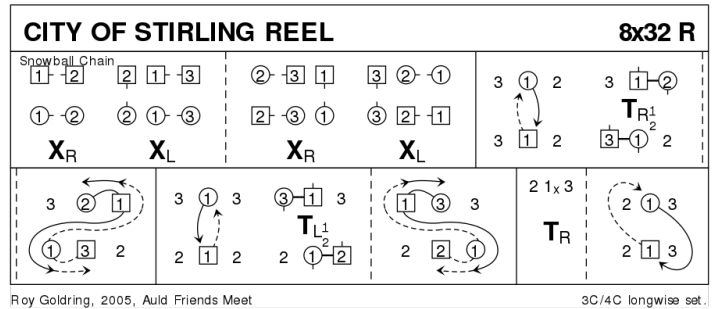

5 THE FIRST RAIN OF SPRING J32 · 3/3L

Wouter Joubert: RSCDS XLIX 4 · Crib: MiniCribbs · Diagram: Keith Rose's Diagrams

- 1-8 1s dance down, cast up round 3s, meet, dance up to 1st place facing out. 1s+2s 1/2 turn (Men LH, Ladies RH)
- 9-16 2s+1s dance double Figs 8 (1s cross up, 2s cast to start)
- 17-20 1s+3s 3/4 turn RH into line up/down in middle facing partner & set
- 21-28 1s+3s dance 1/2 Celtic Reel:
 21-22 1s+3s pass partner RSh
 23-24 1M+3L dance clockwise **while**
 1L+3M dance 3/4 round each other LSh to face partners in line across
 25-26 1s+3s pass partner RSh
 27-28 1L+3M dance clockwise **while** 1M+3L dance 3/4 round each other LSh to face partners in line up/down set
- 29-32 3s+1s 3/4 turn partners RH to sidelines & 2s+3s+1s set

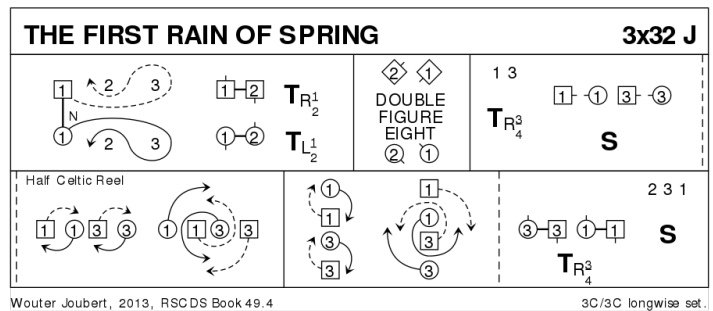

6 THE ROAD TO MCGREGOR S32 · 4/4L

Andrew Hodgson · Diagram: Keith Rose's Diagrams

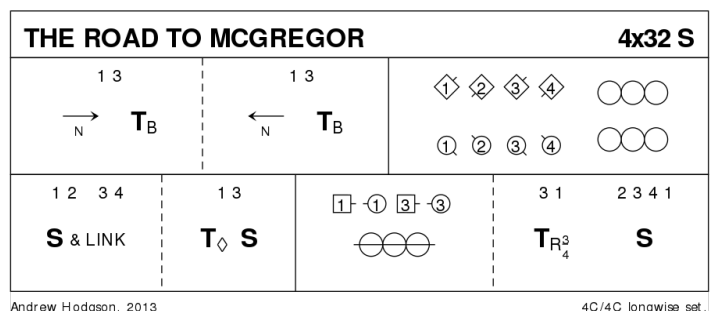

7 JAYWALKING (TYLER)

8 REFRESHMENT BREAK

9 THE AMBASSADORS' REEL R32 · 3/4L

Susi Mayr: Vienna Book of Scottish Country Dances · Crib: Eric Ferguson's SCD Cribbs · Diagram: Keith Rose's Diagrams

- 1- 1c dance between 2c and cast up ; ½ Fig8 down round 2c,
- 9- 1c dance down between 3c (2c up) ; cast up, ½ Fig8 down round 3c (2,1,3)
- 17- 1c turn 1cnr RH, pass Rsh, turn 2cnr RH, pass Rsh into
- 25- Circle6 and back (2,1,3)

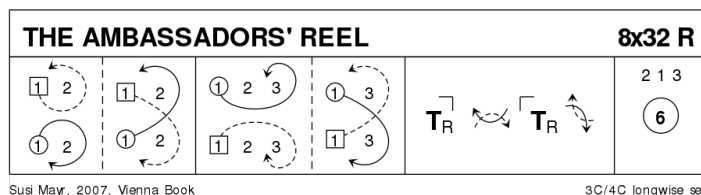

Deviser's Note: 1c can choose handing freely ; the timing is fluid, the barring only an approximation

10 BEST SET IN THE HALL J32 · 3/4L

Helen Greenwood: RSCDS XLVI 7 · Crib: Eric Ferguson's SCD Cribbs · Diagram: Keith Rose's Diagrams

- 1- 1c set | 1W (1M follows) casts off 2, crosses, W dances up behind M line, and M dances up the middle, 1c face 1cnr (2c up)
- 9- 1c set to 1cnr | 1c cast Rsh round each other to 3cnr position **while{2}** 1cnrs dance into centre, and swivel R to face own cnr ; repeat, 1cnrs finishing in exchanged places, and 1c facing 2cnr
- 17- Repeat with 2cnrs (3x,1x,2x)
- 25- All chase clw ½ round ; all turn RH. (2,1,3)

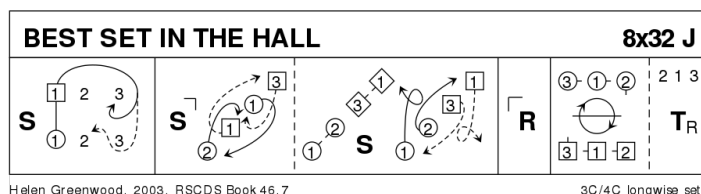

To: Auckland Region President, Campbell MacKay, nov. 2003

11 THE DREAM CATCHER S96 · 4S

Eileen Orr: RSCDS XLV 9 · Crib: Eric Ferguson's SCD Cribbs · Diagram: Keith Rose's Diagrams

Part 1

- 1- All Circle8 and back
- 9- The Swirl: 1c+3c turn RH into Allemande hold facing in | dance Lsh round other C half way ; 1c+3c LHA, on [16] let go and swivel L to face side couples, BtoB with P, 1c below 3c
- 17- Parallel Rsh Reels4 across, finish as at start
- 25- All set | 1M+3W & 3M+1W NHJ dance out between side couple, cross and cast to own places, change place with P RH

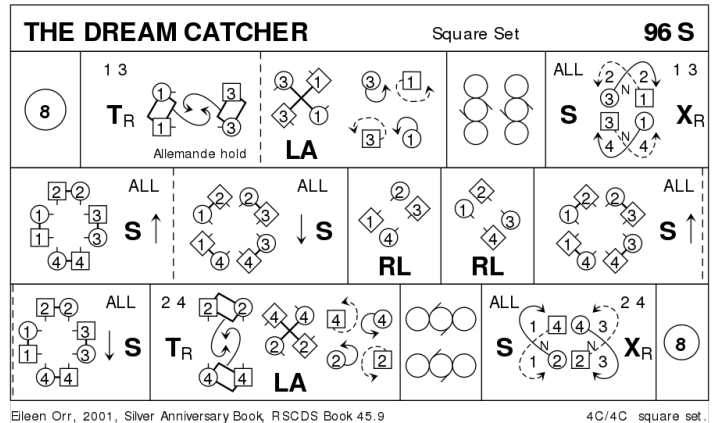

Part 2

- 1- All set | advance to middle and form circle ; retire with cnr | set
- 9- 1W+4M & 3W+2M R&L, starting across the set
- 17- 1M+2W & 3M+4W R&L, starting across the set
- 25- All set | advance to middle and form circle ; retire with P | set

Part 3

- 1-24 2c+4c starting, repeat part 1, 9-32 in the other orientation (The Swirl, Reels4 up/dn, return to places)
- 25- All Circle8 and back

12 CATCH THE WIND R32 · 3/4L

Romaine Butterfield: RSCDS XLV 5 · Crib: Eric Ferguson's SCD Cribbs · Diagram: Keith Rose's Diagrams

- 1- 1c set | cast off (2c up) ; ½Fig8 up (2,1x,3)
- 9- 1c set twice, on [11-12] 1W swivels R to face out ; 1W (1M following) casts R round 2M and down middle to finish 1W between 3c facing 3M, and 1M between 2c facing 2M.
- 17- 1M+2c & 1W+3c Rsh reels3 across
- 25- 1W (1M following) casts R round 3M and cross to 2pl ; 1c turn RH (2,1,3)

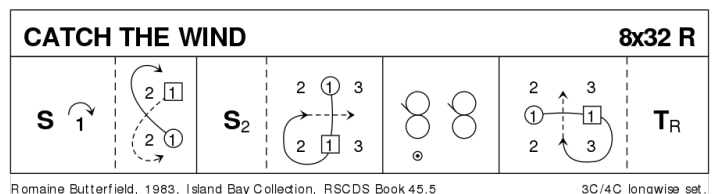

The original tune is a hornpipe

13 NEVER AT SEA R48 · 6/6L

J C Haddow · Crib: Eric Ferguson's SCD Crib · Diagram: Keith Rose's Diagrams

On second chord, the bottom three couples cross to opposite side (1,2,3,4x,5x,6x)

This dance is centro-symmetric; both ends do identical figures

- 1- 1c+6c cross RH | cast inwards (2c+5c to end) ; cross LH | cast to middle (3c+4c to end) (2,3,1,6x,4x,5x)
- 9- 1M+6W & 6M+1W take promhold Lsh Reels3 across with 4c/3c resp. (2,3,1,6x,4x,5x)
- 17- 2c+3c+1c & 5c+4c+5c mirror Reels3 on the sides, 1c&6c start inwards towards own end (2,3,1,6x,4x,5x)
- 25- 1c+6c R&L
- 33- 2c&5c cross RH while{} 3c+1c & 6c+4c ½ RHA | on sidelines change place LH between 1pl/2pl, 3pl/4pl and 5pl/6pl (1x,2x,4,3x,5,6) ; repeat {4}
- 41- repeat [33-36] ; All turn P RH (5,4,6,1,3,2)

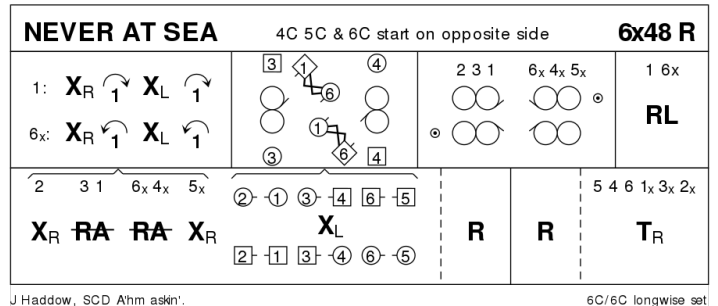

Dance 3 times to end 6 5 4 3 2 1 or 6 times to end 1 2 3 4 5 6

14 THE MINISTER ON THE LOCH S32 · 3/3L

Roy Goldring: Magazine Dances 2005-2009 · Crib: Eric Ferguson's SCD Crib · Diagram: Keith Rose's Diagrams

- 1- 1c+2c Pousette
- 9- 1c dance down 2 places, turn BH ; dance up 2 places, turn BH, open upwards and face out
- 17- 1c+3c DbIFig8 round 2c, 1c casting, 3c crossing up to begin, 1c finish facing out for
- 25- 1W+2W & 1M+2M turn EH 1½ ; 1c+3c repeat (2,3,1)

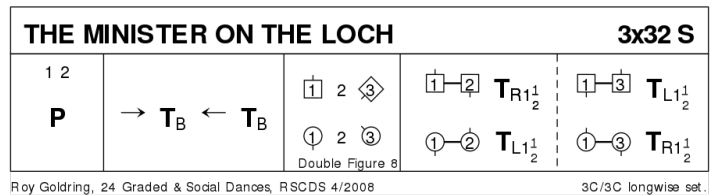

15 MAIRI'S WEDDING R40 · 3/4L

James B Cosh: Twenty Two SCD · Crib: Eric Ferguson's SCD Crib · Diagram: Keith Rose's Diagrams

- 1- 1c turn RH | cast (2c up) ; turn LH to face 1cnrs
- 9- 1c ½Reel4 with 1cnrs (pass P Lsh) ; Repeat with 2cnrs
- 17- Repeat with 3cnrs (1cnr person) ; Repeat with 4cnrs (2cnr person)
- 25- 1W+2c & 1M+3c Reels3 across, Lsh to 1cnr
- 33- 2c+1c+3c circle6 and back

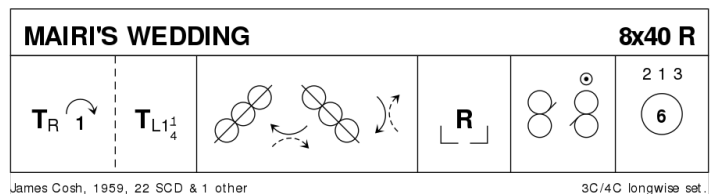

Note: Cosh explicitly tells 1c to pass Lsh in [9-24]; however the Rsh pass is quite common, and nicknamed »Mairi's Divorce«.

16 POLHARROW BURN R32 · 5/5L

Hugh Foss: Magazine Dances 2005-2009 · Crib: Eric Ferguson's SCD Cribbs · Diagram: Keith Rose's Diagrams

- 1- 1c+3c cross | cast off (2c+4c up) ; ½ Fig8 up round 2c/4c (2,1,4,3,5)
 9- 1c+3c turn P RH ; turn P LH to face 1cnrs **while**{8} 2c+5c cross RH and chase clw. to other end of set (2M & 5W leading P) (5,1,4,3,2)
 17- diag. ½Reels4 with 1cnrs (1diags.) (pass Lsh) ; repeat on 2diags.
 25- Repeat with 3cnrs (1diags) ; 1c+3c turn LH and cast off on own side (4c+5c up) (2,4,1,5,3)

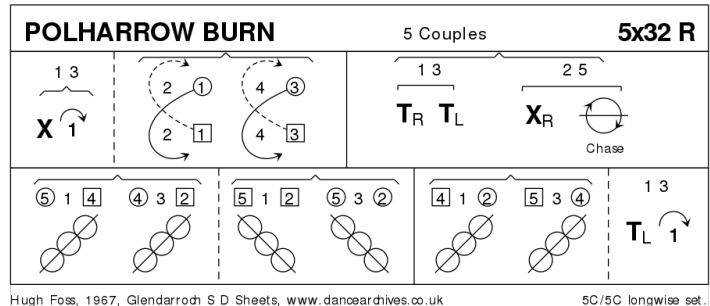

17 LAND OF THE HEATHER HILLS S32 · 4/4L

Barry Priddey: Capercaillie Book · Crib: MiniCribbs · Diagram: Keith Rose's Diagrams

3s & 4s start on opp sides

- 1-8 1s & 4s set, 1L followed by partner cast to dance Fig of 8 on Ladies side round 2L+3M & end diagonally facing 2M (partner behind her) **while** 4L followed by partner cast to dance Fig of 8 round 3L+2M & ends diagonally facing 3M (2s & 3s step up/down on bars 7-8)
 9-16 1s+4s dance 1/2 diagonal Alternating Tandem reel of 4 with 1st corners, 1s+4s pass LSh (1/2 turning other partner LH) & dance a 1/2 Alternating Tandem reel of 4 with 2nd corners & end passing LSh (1/2 turning other partner) & face 1st corners
 17-24 1s+4s repeat above reels, pass LSh & 1/2 turn other partner to end singly on opposite sides (from which they started) order 2 (1) 4 (3)
 25-32 All dance 1/2 reels of 4 on sides, 1s+4s do not pass LSh but turn 2H to (3)(1) 4 2, all set & cross RH

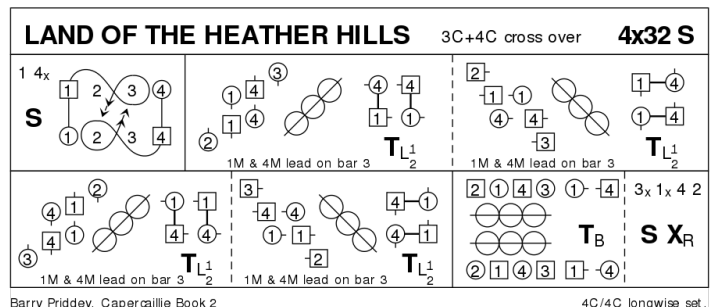

18 BRATACH BANA R32 · 3/4L

John Drewry: *Bon Accord Book of Scottish Country Dances* · Crib: *Eric Ferguson's SCD Cribs* · Diagram: *Keith Rose's Diagrams*

- 1- 1c turn RH | cast off (2c up) ; ½ Fig8 to R around 1cnr (to 2,1x,3)
- 9- ½Reel3 on sides (Rsh to 2cnr) ; ½Reel3 across (Lsh to 3cnr position), finish on sides (3x,1,2x)
- 17- 1c turn ¾ LH, Turn 1cnr person (3cnr position) RH ; pass Rsh, turn 2cnr person (4cnr position) ¾ RH to promhold (cnr on the right)
- 25- These pairs change places Rsh | drop left hand and turn RH ½ to sidelines ; half diagonal R&L (1st diagonal direction)

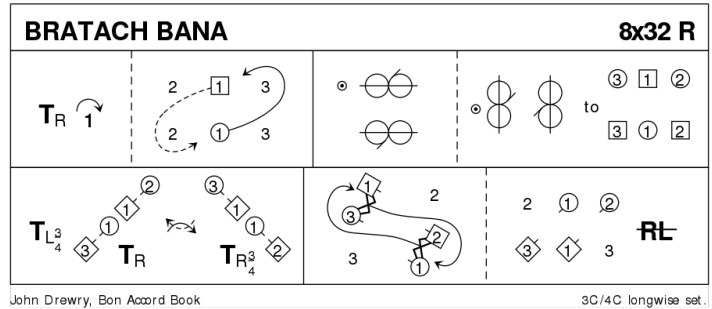

John Drewry, *Bon Accord Book*

3C/4C longwise set.

Note on [27-28]: originally 2 PdB. modified by Drewry to SkCh. O. Otto says best variant is corners in PdB, 1c in SkCh