

Welcome Dance Cape Town 19 October 2017

1 THE FERRYBOAT J32 · 1C

Carolyn Hunt: *Let's All Dance* · Crib: *MiniCrib*s · Diagram: *Keith Rose's Diagrams*

- 1-8 All Men Adv+Ret & all circle left
- 9-16 All Ladies Adv+Ret & all circle right
- 17-24 All dance Grand Chain (pass partner RH to start) & face 5th person (new partner) joining both hands
- 25-32 All Slip-Step into centre (2 bars) & back, all turn new partners RH

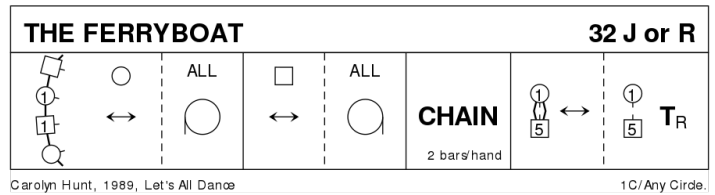

2 PELORUS JACK J32 · 3/4L

Barry Skelton: *RSCDS XLI 1* · Crib: *MiniCrib*s · Diagram: *Keith Rose's Diagrams*

- 1-8 1s cross RH & cast 1 place, dance RH across with 3s & 1s end with Man facing his 1st corner with his partner behind him
- 9-16 1s dance Alternating Tandem 1/2 reel of 3 with 1st corners, 1s dance Alternating Tandem 1/2 reel with 2nd corners
- 17-24 1s dance Alternating Tandem 1/2 reels of 3 with Ladies 1st corner (pstrn), 1s dance Alternating Tandem 1/2 reel with Ladies 2nd corner (pstrn)
- 25-32 1M followed by partner dance into LH across with 2s, 1s retain LH & 1/2 turn to own sides & 2s+1s+3s set

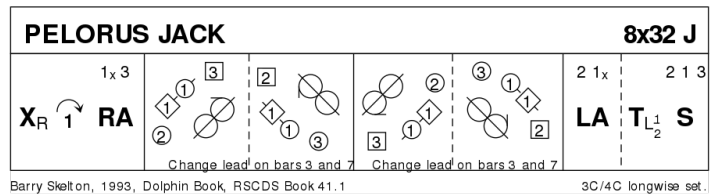

3 MISS MILLIGAN'S STRATHSPEY S32 · 3/4L

RSCDS: *The Leaflet Dances with Music* · Crib: *MiniCrib*s · Diagram: *Keith Rose's Diagrams*

- 1-8 1s+2s circle 4H round to left, 1s turn to face 2s & set, 1s cast **while** 2s dance up
- 9-16 2s+1s+3s dance reflection reels of 3 on own sides 1s dancing in between 3s to start
- 17-24 2s+1s+3s set, 2s+1s 1/2 turn LH, 1s followed by 2s lead down between 3s, cross & cast up on own sides
- 25-32 1s+2s dance the Knot

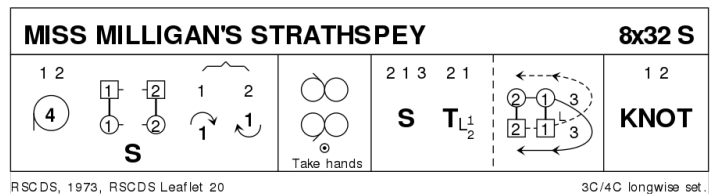

4 THE CRANBERRY TART J32 · 3/4L

Terry Glasspool: Dances from the Seven Year Itch · Crib: MiniCribs · Diagram: Keith Rose's Diagrams

- 1-8** 1M sets & casts 1 place, sets & petronella turns between 3s facing up **while** 1L stands for 2 bars then sets, casts 1 place & sets
- 9-16** 1M sets in line with 3s & all 3 Adv+Ret then 1M advances to partner **while** 1L petronella turns between 2s & sets in line with 2s then all 3 Adv+Ret
- 17-24** 1L followed by partner dances reel of 3 across with 2s (RSh to 2L) to end in 2nd place own sides
- 25-32** 1s dance RSh reels of 3 on sides giving RSh to 3s

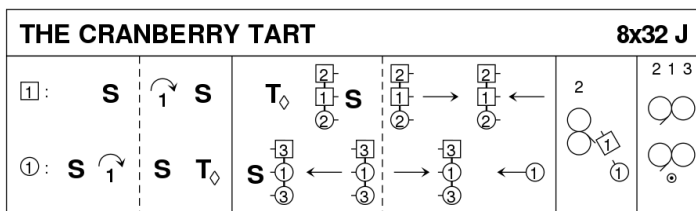

Terry Glasspool, 7 Year Itch

3C/4C longwise set.

5 UNDER AFRICAN SKIES R32 · 3/4L

Roy Goldring: Many Happy Hours - Pretoria 35th · Crib: MiniCribs · Diagram: Keith Rose's Diagrams

- 1-4** 1M+3L Adv to centre & set turning right about to face partner
- 5-8** 1M & 3L 1/2 turn partner RH retaining hold & Bal-in-line in diagonal lines of 3 (1s with 2M, 3s with 2L)
- 9-16** 1s+2M & 3s+2L dance parallel reels of 3 (1s & 3s giving Rsh to partner to start)
- 17-24** 1M & 3L (followed by partner) chase clockwise to 3rd/1st places & all turn RH into Allemande hold. 3 2 1
- 25-32** 3s+2s+1s dance Allemande but on bars 31/32 1s cast to 2nd place as 2s dance up to 1st place). 2 1 3

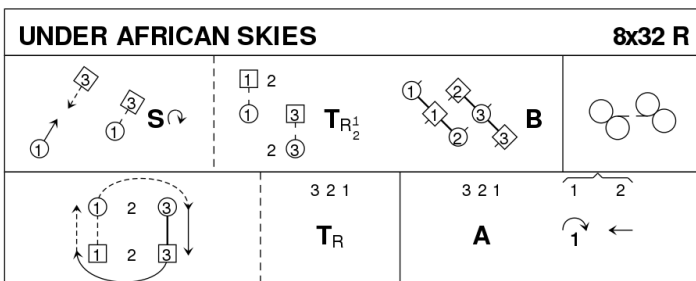

Roy Goldring, Many Happy Hours

3C/4C longwise set.

6 CHERRYBANK GARDENS S32 · 3/3L

John Drewry: Bankhead Book Part 1 · Crib: MiniCribs · Diagram: Keith Rose's Diagrams

- 1-8** 1s+2s set & Petronella-in-tandem twice to end with 2s+1s on opposite sides having changed places
- 9-16** 2s+1s set & 2s cross RH & 1s LH, 1L dances RH across with 2s & 1M with 3s
- 17-24** 1s+3s Set+Link & circle 4H round to left
- 25-32** 2s+3s+1s dance Grand Chain (2s crossing to commence)

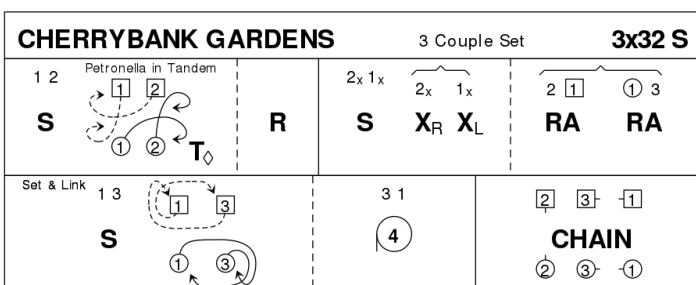

John Drewry, 1991, Bankhead 1

3C/3C longwise set.

7 MISS HILARY ANN J40 · 3/4L

Barbara Bradley · Crib: MiniCribbs · Diagram: Keith Rose's Diagrams

- 18** 1M+2L set & 3/4 turn RH, 2L dances up & casts round 1L back to place **while** 1M dances down & casts up round 2M back to place
- 9-16** 1L+2M set & 3/4 turn LH, 2M dances up & casts round 1M back to place **while** 1L dances down & casts up round 2L back to place
- 17-24** 1s turn RH, lead down 2 places, cross & cast up round 3s to 2nd places
- 25-32** 2s+1s+3s dance reflection reels of 3 on sides (1s in & up to start) & 1s end facing 1st corners
- 33-40** 1s dance "Hello-Goodbye" setting ending with petronella turn to 2nd places

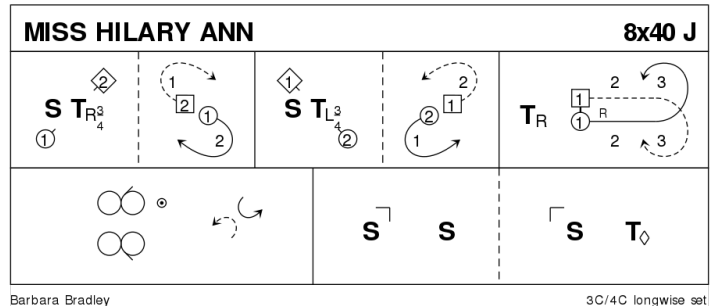

BREAK

8 NEVER AT SEA R48 · 6/6L

J C Haddow · Crib: MiniCribbs · Diagram: Keith Rose's Diagrams

4s & 5s & 6s start on opp sides

- 1-8** 1s cross RH & cast to 2nd place, cross LH & cast to 3rd place **while** 6s cross RH & cast to 5th place, cross LH & cast to 4th place
- 9-16** 1M+6L Prom hold dance reel of 3 with 4s (pass 4M LSh to start) **while** 6M+1L dance reel of 3 with 3s (pass 3M LSh) end 1s in 3rd place side by side facing up & 6s in 4th place facing down ready for:..
- 17-24** 1s & 6s dance reflection reels on sides dancing up/down between 3s/4s to start
- 25-32** 1s+6s dance R&L ending with 1s facing up & 6s facing down
- 33-36** End couples cross RH **while** cpl in 2nd+3rd pl also cpl in 4th+5th pl dance 1/2 RH across & all (1st+2nd pl, 3rd+4th pl, 5th+6th pl) change pl LH on side
- 37-40** Repeat bars 33-36
- 40-44** Repeat bars 33-36
- 45-48** All turn partners RH 5 4 6(1)(3)(2)

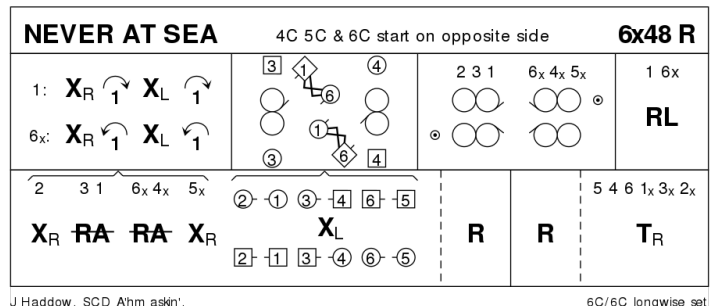

Dance 3 times to end 6 5 4(3)(2)(1) or 6 times to end 1 2 3(4)(5)(6)

9 SUGAR CANDIE S32 · 3/4L

RSCDS XXVI 9 · Crib: MiniCribs · Diagram: Keith Rose's Diagrams

- 1-8** 1s set & cast 1 place, cross passing LSh & cast RSh round their 1st corner into centre ending BtoB (Lady facing up, Man down)
- 9-16** 1L circle left with 2s & 1M with 3s, turn to face partner & set, 3/4 turn partner 2H to end facing 1st corners
- 17-24** 1s turn 1st corner RH, partner LH, 2nd corner RH, partner LH & end facing 1st corners
- 25-32** 1s dance Reel of 3 on opposite sides passing 1st corner LSh & cross RH to 2nd place own sides

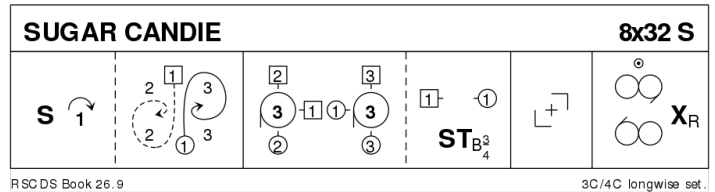

10 SETON'S CEILIDH BAND J64 · 4/4L

A Bruce Fordyce: The Bruce Fordyce Memorial Collection · Crib: MiniCribs · Diagram: Keith Rose's Diagrams

- 1-8** 1s cross RH & cast 1 place, lead down between 3s & cast down behind 4s
- 9-16** 1s dance reflection reels of 3 on opposite sides beginning by dancing up between 4s
- 17-24** 1s cross RH & cast up 1 place, lead up between 3s & cast up behind 2s
- 25-32** 1s dance reels of 3 on own sides beginning by dancing down between 2s
- 33-40** 1s cross RH & cast down 1 place to give RH to partner & LH to 1st corners, Bal-in-Line & turn partner RH to give LH to 2nd corners
- 41-48** Bal-in-Line & 1s dance out & cast down behind 3s, lead up to top crossing to 1st place own sides
- 49-60** 1L+2L & 1M+2M change places RH on sides & 2s+1s cross over LH, repeat with 3s & 4s until reaching the bottom of the set
- 61-64** All turn RH 1.1/2 times

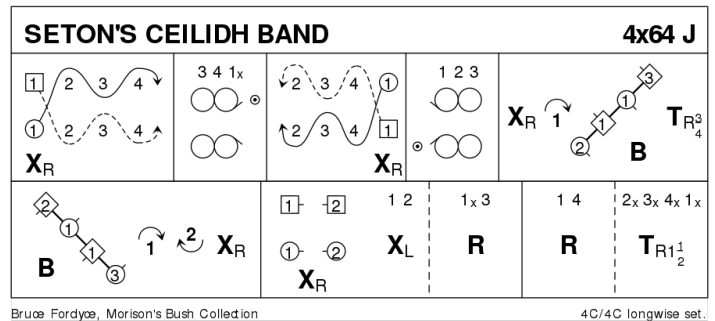

11 FLOWERS OF EDINBURGH R32 · 3/4L

RSCDS I 6 · Crib: MiniCribs · Diagram: Keith Rose's Diagrams

- 1-8** 1L followed by partner casts below 3s, 1L crosses & dances up behind Men as 1M dances up centre to 1st places on opposite side & 1s set
- 9-16** 1M followed by partner repeat above Fig & set in own places
- 17-24** 1s lead down the middle & back
- 25-32** 1s+2s dance Poussette. 2 1 3

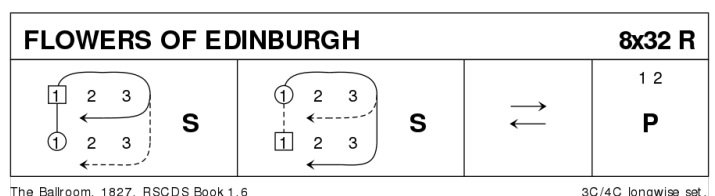

12 THE DREAM CATCHER S96 · 4S

Eileen Orr: RSCDS XLV 9 · Crib: MiniCribbs · Diagram: Keith Rose's Diagrams

- 1-8 All circle 8H round & back
 9-16 1s+3s dance the Swirl: Turn partner RH into Allemande hold & dance LSh round other couple 1/2 way, dance LH across & swirl to face side couples (BtoB with ptr & Lady facing Man)
 17-24 All dance reels of 4 across
 25-32 All set & dancing couples dance out between side couples, cross & cast to change places RH with partner back into places
 33-40 All set & advance with partners, retire diagonally with corners & set
 41-48 1L+4M dance R&L with 3L+2M (on diagonal)
 49-56 1M+2L dance R&L with 3M+4L (other diagonal)
 57-64 All set with corners, Adv+Ret with partners & set
 65-88 2s & 4s repeat bars 9-32
 89-96 All circle 8H round & back

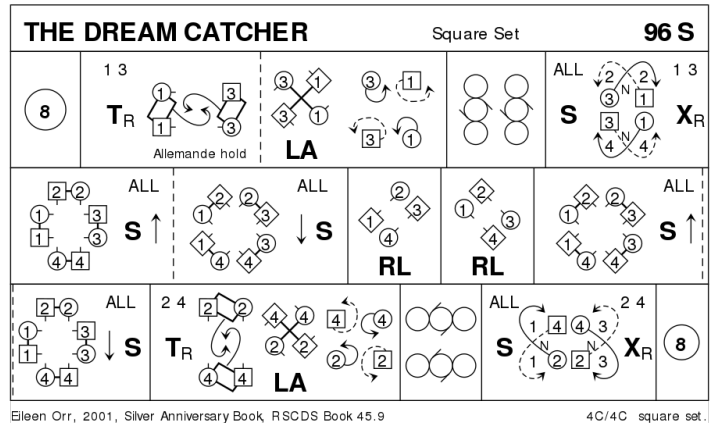

13 ST ANDREW'S FAIR J32 · 3/4L

Roy Goldring: Five Scottish Country Dances 1982 · Crib: MiniCribbs · Diagram: Keith Rose's Diagrams

- 1-8 1s cross RH, cast 2 places, cross LH below 3s & cast up to 2nd place own sides
 9-16 2s+1s+3s 1/2 turn RH retain hands & all set (M face down & L up) 2L leads Ladies across & down own side **while** 3M leads Men across & up
 17-24 3s+1s+2s circle 6H round & back
 25-32 3s+1s+2s 1/2 turn LH retain hands & all set (M face up & L down) 2L leads Ladies across & up own side **while** 3M leads Men across & down

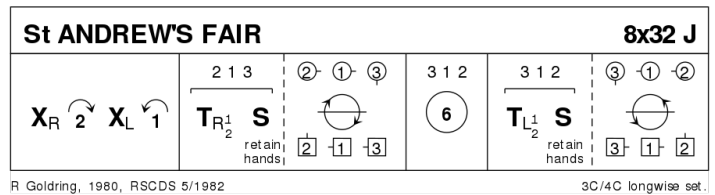

14 THE DEIL AMANG THE TAILORS R32 · 3/4L

RSCDS XIV 7 · Crib: MiniCribbs · Diagram: Keith Rose's Diagrams

- 1-8 1s+2s set & dance RH across 1/2 way, set & dance LH across 1/2 way back to place
 9-16 1s lead down the middle & back to top
 17-24 1s+2s dance Allemande
 25-32 2s+1s+3s circle 6H round & back

