

# ZA 2015-12-05 Lynfrae End-of-year Party

## 1 PELORUS JACK J32 · 3/4L

Barry Skelton: RSCDS XLI 1 · Crib: MiniCribs · Diagram: Keith Rose's Diagrams

**1-8** 1s cross RH & cast 1 place, dance RH across with 3s & 1s end with Man facing his 1st corner with his partner behind him

**9-16** 1s dance Alternating Tandem 1/2 reel of 3 with 1st corners, 1s dance Alternating Tandem 1/2 reel with 2nd corners

**17-24** 1s dance Alternating Tandem 1/2 reels of 3 with Ladies 1st corner (pstrn), 1s dance Alternating Tandem 1/2 reel with Ladies 2nd corner (pstrn)

**25-32** 1M followed by partner dance into LH across with 2s, 1s retain LH & 1/2 turn to own sides & 2s+1s+3s set

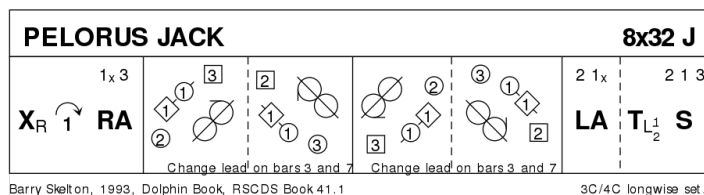

## 2 POLHARROW BURN R32 · 5/5L

Hugh Foss: Magazine Dances 2005-2009 · Crib: MiniCribs · Diagram: Keith Rose's Diagrams

**1-8** 1s & 3s cross RH, cast 1 place & dance 1/2 Fig of 8 round couple above them

**9-16** 1s & 3s turn RH then LH (long turns) to face 1st corners **while** 2s & 5s 1/2 turn RH & chase clockwise to other end of set

**17-24** 1s & 3s dance 1/2 Reels of 4 with 1st corners then 2nd corners

**25-32** 1s & 3s dance 1/2 Reel of 4 with 3rd corner, turn partner LH & cast down 1 place own sides. 2 4 1 5 3

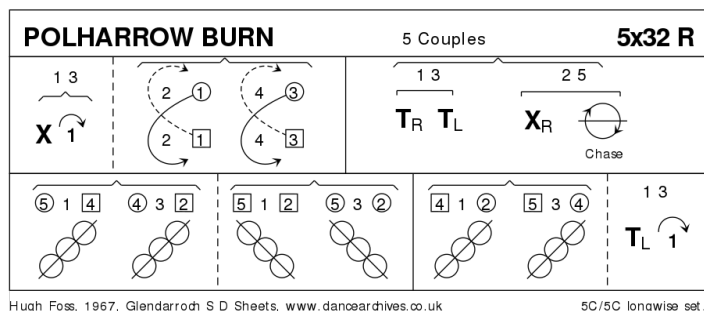

## 3 ANNA HOLDEN'S STRATHSPEY S32 · 2/4L

John Drewry: RSCDS XLII 2 · Crib: MiniCribs · Diagram: Keith Rose's Diagrams

**1-8** 1s+2s dance RH across, 1s cross down to 2nd pl as 2 cast up then 1M+2L turn LH as 1L+2M turn RH into a line across (1s between 2s) facing down

**9-16** 1s+2s dance down in line, 1s turn & face up as 2s turn in behind, dance up, 1s casting to 2nd place opp sides as 2s dance to 1st place own sides

**17-24** 2M+1L also 2L+1M set & Petronella turn-in-tandem into middle, set & Petronella turn-in-tandem to sides

**25-32** 1s+2s set, circle 4H round 1/2 way; 1s turn 2H 1.1/2 times to 2nd place own side

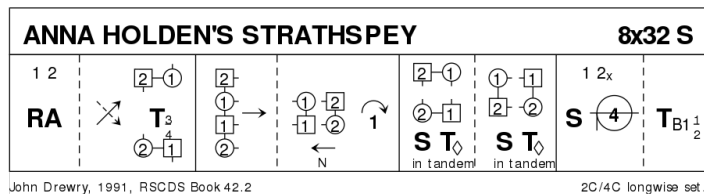

## 4 NEVER AT SEA R48 · 6/6L

J C Haddow · Crib: MiniCribbs · Diagram: Keith Rose's Diagrams

4s & 5s & 6s start on opp sides

- 1-8** 1s cross RH & cast to 2nd place, cross LH & cast to 3rd place **while** 6s cross RH & cast to 5th place, cross LH & cast to 4th place
- 9-16** 1M+6L Prom hold dance reel of 3 with 4s (pass 4M LSh to start) **while** 6M+1L dance reel of 3 with 3s (pass 3M LSh) end 1s in 3rd place side by side facing up & 6s in 4th place facing down ready for:..
- 17-24** 1s & 6s dance reflection reels on sides dancing up/down between 3s/4s to start
- 25-32** 1s+6s dance R&L ending with 1s facing up & 6s facing down
- 33-36** End couples cross RH **while** cple in 2nd+3rd pl also cple in 4th+5th pl dance 1/2 RH across & all (1st+2ndpl, 3rd+4thpl, 5th+6thpl) change pl LH on side
- 37-40** Repeat bars 33-36
- 40-44** Repeat bars 33-36
- 45-48** All turn partners RH 5 4 6(1)(3)(2)

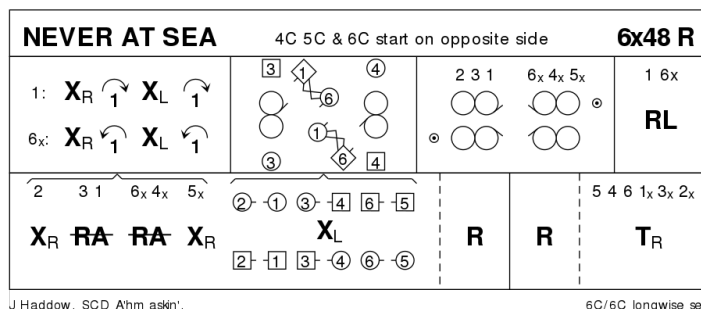

Dance 3 times to end 6 5 4(3)(2)(1) or 6 times to end 1 2 3(4)(5)(6)

## 5 THE FIRST RAIN OF SPRING J32 · 3/3L

Wouter Joubert: RSCDS XLIX 4 · Crib: MiniCribbs · Diagram: Keith Rose's Diagrams

- 1-8** 1s dance down, cast up round 3s, meet, dance up to 1st place facing out. 1s+2s 1/2 turn (Men LH, Ladies RH)
- 9-16** 2s+1s dance double Figs 8 (1s cross up, 2s cast to start)
- 17-20** 1s+3s 3/4 turn RH into line up/down in middle facing partner & set
- 21-28** 1s+3s dance 1/2 Celtic Reel:  
**21-22** 1s+3s pass partner RSh  
**23-24** 1M+3L dance clockwise **while** 1L+3M dance 3/4 round each other LSh to face partners in line across  
**25-26** 1s+3s pass partner RSh  
**27-28** 1L+3M dance clockwise **while** 1M+3L dance 3/4 round each other LSh to face partners in line up/down set
- 29-32** 3s+1s 3/4 turn partners RH to sidelines & 2s+3s+1s set

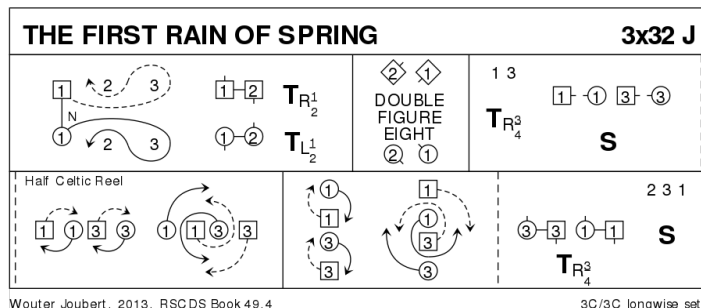

## 6 LAND OF THE HEATHER HILLS

S32 · 4/4L

Barry Priddey: Capercaillie Book · Crib: MiniCrib · Diagram: Keith Rose's Diagrams

3s & 4s start on opp sides

- 1-8** 1s & 4s set, 1L followed by partner cast to dance Fig of 8 on Ladies side round 2L+3M & end diagonally facing 2M (partner behind her) **while** 4L followed by partner cast to dance Fig of 8 round 3L+2M & ends diagonally facing 3M (2s & 3s step up/down on bars 7-8)
- 9-16** 1s+4s dance 1/2 diagonal Alternating Tandem reel of 4 with 1st corners, 1s+4s pass LSh (1/2 turning other partner LH) & dance a 1/2 Alternating Tandem reel of 4 with 2nd corners & end passing LSh (1/2 turning other partner) & face 1st corners
- 17-24** 1s+4s repeat above reels, pass LSh & 1/2 turn other partner to end singly on opposite sides (from which they started) order 2 (1) 4 (3)
- 25-32** All dance 1/2 reels of 4 on sides, 1s+4s do not pass LSh but turn 2H to (3)(1) 4 2, all set & cross RH

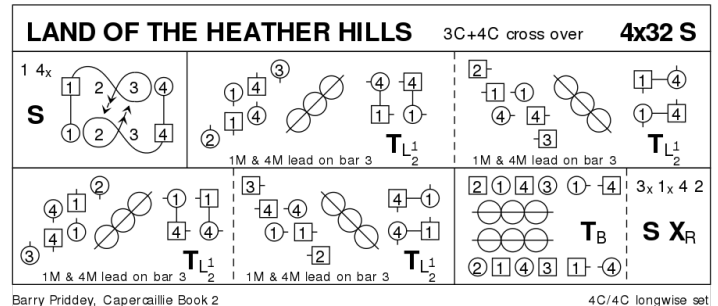

## 7 J. B. MILNE R32 · 3/4L

Hugh Foss: A Guide to Scottish Country Dancing · Crib: MiniCrib · Diagram: Keith Rose's Diagrams

- 1-8** 1M+2L set advancing & turn RH, 1L+2M set advancing & turn RH
- 9-16** 1s set to each other & turn 2H, cast to 2nd place & Petronella turn to Lady between 2s & Man between 3s
- 17-24** 1s set & 3/4 turn RH **while** 2s+3s change places RH on sides & set, 1s repeat but 2s & 3s cross RH & set
- 25-32** 1s set & change places RH **while** 2s+3s change places RH on sides & set, 1s cast round corner to 2nd pl own sides as 2s+3s cross RH & all set

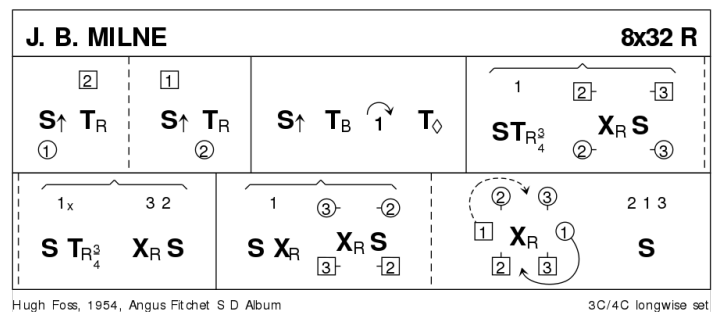

## 8 A TRIP TO BAVARIA R32 · 4/4L

James MacGregor-Brown: A Guide to Scottish Country Dancing · Crib: MiniCrib · Diagram: Keith Rose's Diagrams

- 1-4** 1s & 4s cross RH **while** 2s+3s dance 1/2 RH across, 1s+3s & 2s+4s change places LH on sides
- 5-16** Repeat 1-4 another 3 times (end cpls cross RH, middle cpls 1/2 RH across; cpls in 1st+2nd place also 3rd+4th place change places LH) All finish in original places
- 17-24** 1s set to 2s & cross over to face 3s, set & cross to face 4s
- 25-32** 1s set to 4s & cross over to 4th place on opposite sides, all Adv+Ret 2 steps & 1s change places RH (2H popular) to retire to own sides

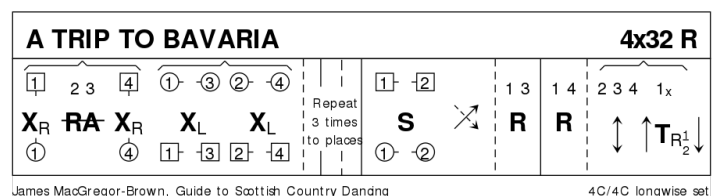

## 9 GYPSY DREAMS S32 · 2/4L

Terry Glasspool: *An Itch to Dance* · Crib: *MiniCrib*s · Diagram: *Keith Rose's Diagrams*

- 1-8** 1s cross RH & 1/2 turn 2s LH on sides, 2s+1s chase anticlockwise 1 pl & 3/4 turn ptrns LH into centre to a line of 4 across (Ladies BtoB facing ptrns)
- 9-16** All dance Gypsy Pousette :  
Box setting:  
**9** All set to the right turning 1/4 turn to right  
**10** All set to the left (facing away from partner) & 1/4 turn to right  
**11** All set to the right (facing partner, Men pass BtoB) & 1/4 turn to right  
**12** All set to the left (facing away from partner & passing BtoB) & no turn, partners now facing away from each other (but not lined up back to back)  
Gypsy turn:  
**13-14** All cast to right & dance around partners 1/2 way to face partners  
**15-16** All 3/4 turn partners 2H into a line across, Men back to back in middle
- 17-24** 1s+2s dance reel of 4 across ending in prom hold, 2s facing down & 1s facing up (Men with partner on their right)
- 25-32** 1s+2s wheel round anticlockwise 1/4 way to dance the Tournee :  
1s+2s dance into prom hold (Men with prtnr on right, 1s face M's side & 2s L's side), couples 1/2 wheel anticlockwise & Men turn Ladies into middle, both couples turn 1.1/2 times (2s RH, 1s LH) & dance out to places

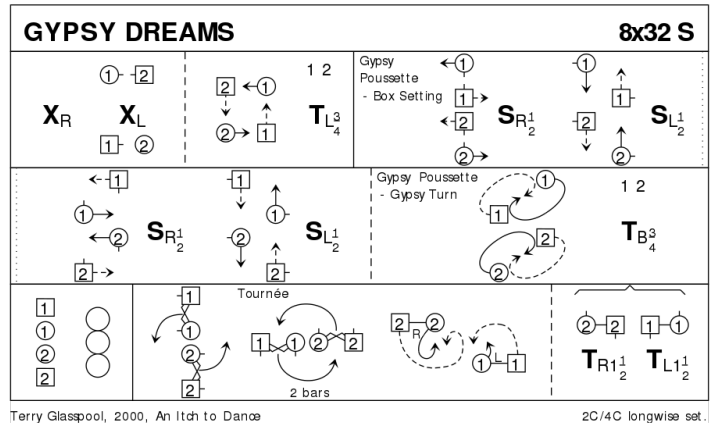

## 10 THE PIPER AND THE PENGUIN R88 · 4S

Roy Goldring: *The Scotia Suite of Scottish Country Dances* · Crib: *MiniCrib*s · Diagram: *Keith Rose's Diagrams*

- 1-8** Ladies dance RSh round their corners, dance RH across ending in centre
- 9-16** Ladies dance LSh round their partners, dance LH across & back to places
- 17-24** Men dance RSh round their partners, dance RH across ending in centre
- 25-32** Men dance LSh round corners, dance LH across & back to places
- 33-40** 1s & 3s turn partners RH 1.1/4 times, Men followed by partners dance out between side couples & back to places (1M thru 4s & 3M thru 2s)
- 41-48** 1s+3s dance R&L
- 49-64** 2s+4s repeat bars 33-48
- 65-72** Ladies dance in turning right about to dance out, cast clockwise to opposite Lady's place
- 73-80** Men dance in turning left about to dance out, cast anticlockwise to opposite places
- 81-88** All turn partners RH 1.1/4 times into prom hold, Promenade anticlockwise 1/2 way round to original places

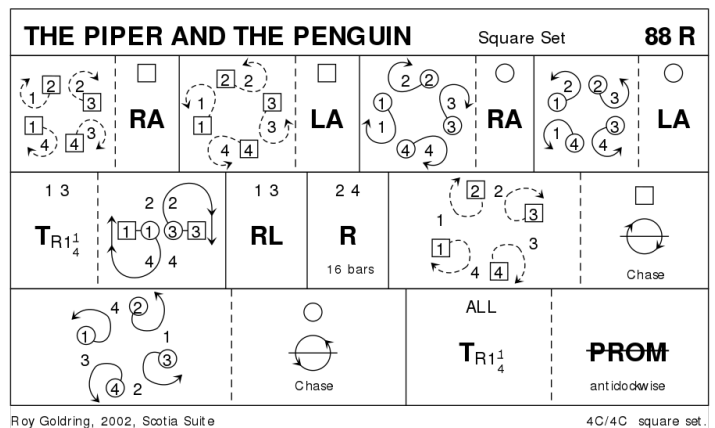

## REFRESHMENT BREAK

## 11 MAIRI'S WEDDING R40 · 3/4L

James B Cosh: *Twenty Two SCD · Crib: MiniCrib*s · Diagram: Keith Rose's Diagrams

- 1-8 1s turn RH & cast to 2nd place, 1s turn LH to face 1st corners
- 9-16 1s dance 1/2 diagonal reel of 4 with 1st corners, 1s dance 1/2 diagonal reel with 2nd corners
- 17-24 1s dance 1/2 diagonal reel with 3rd corner (pstns), 1/2 diagonal reel with 4th corner (pstns)
- 25-32 1s dance reel of 3 across (Lady with 2s, Man with 3s - LSh to 1st corner)
- 33-40 2s+1s+3s circle 6H round & back

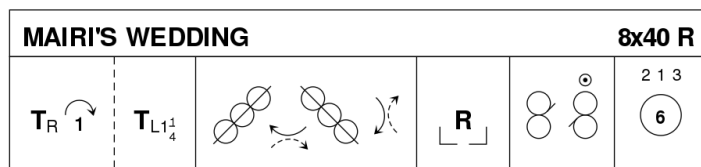

James Cosh, 1959, 22 SCD & 1 other

3C/4C longwise set

## 12 THE BYRON STRATHSPEY S32 · 3/3L

John Drewry: *Deeside Book Part 2 · Crib: MiniCrib*s · Diagram: Keith Rose's Diagrams

- 1-8 All petronella turn into the centre & set to partner, turn 2H 1.1/4 times back to places
- 9-16 1s+2L & 3s+2M dance RH across, 2s pass RSh & dance LH across with other couple
- 17-24 2s in prom hold dance reel of 3 with 1s passing 1L RSh, end 2s in centre at top
- 25-32 2s+1s+3s dance Allemande

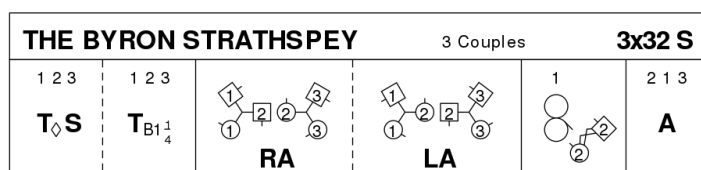

John Drewry, 1975, Deeside Book 2

3C/3C longwise set.

## 13 BEST SET IN THE HALL J32 · 3/4L

Helen Greenwood: *RSCDS XLVI 7 · Crib: MiniCrib*s · Diagram: Keith Rose's Diagrams

- 1-8 1s set & 1L followed by partner casts below 3s, 1L crosses & casts up to face her 1st corner **while** 1M dances up the middle to face 1st corner
- 9-12 1s set to 1st corners & dance RSh round each other into 3rd corner (pstn) **while** 1st corners dance in & turn right about to face their original position
- 13-16 1s+1st crnr person set & 1st crnr persons dance RSh round each other into diag opp cnrs **while** 1s dance in & pivot to right to face 2nd cnrs
- 17-24 1s repeat bars 9-16 with 2nd corners & end passing RSh to 2nd place opposite sides. (3)(1)(2)
- 25-32 2s+1s+3s chase clockwise 1/2 way & turn partners RH

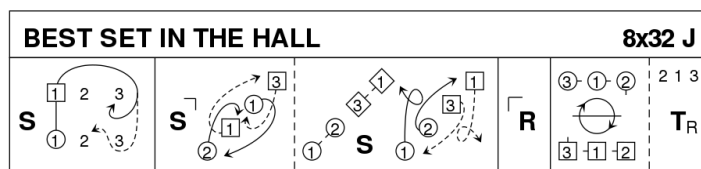

Helen Greenwood, 2003, RSCDS Book 46.7

3C/4C longwise set.

## 14 THE MINISTER ON THE LOCH S32 · 3/3L

Roy Goldring: Magazine Dances 2005-2009 · Crib: MiniCribbs · Diagram: Keith Rose's Diagrams

- 1-8** 1s+2s dance Diamond Poussette  
**9-16** 1s dance down for 2 steps, turn 2H, dance up to top & turn 2H  
**17-24** 1s+3s dance double Fig of 8 round 2s with 1s casting to start  
**25-32** 1M+2M turn LH 1.1/2 times **while** 1L+2L turn RH 1.1/2 times, 1M+3M turn RH 1.1/2 times **while** 1L+3L turn LH 1.1/2 times

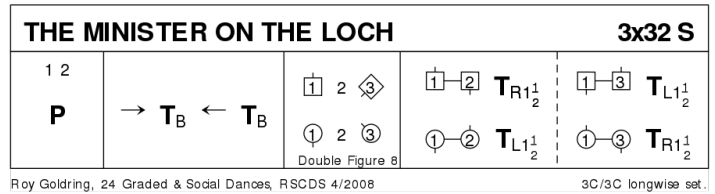

## 15 THE MONTGOMERIES' RANT R32 · 3/4L

Castle Menzies (18C): RSCDS X 1 · Crib: MiniCribbs · Diagram: Keith Rose's Diagrams

- 1-8** 1s cross RH & cast down to 2nd place, cross LH & 1L casts up **while** 1M casts down  
**9-16** 1s dance reels of 3 across, 1L with 2s & 1M with 3s  
**17-24** 1s with nearer hands joined (Lady on Mans left) set to 2L & turn inwards to set to 3M, set to 3L & turn inward & set to 2M  
**25-32** 2s+1s+3s dance reels of 3 on opposite sides 1s giving RSh to 2nd corner, 1s cross RH to 2nd place own sides

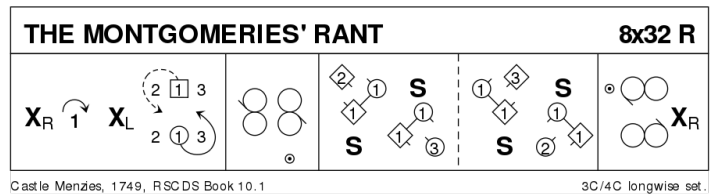

## 16 QUARRIES' JIG J32 · 3/4L

Kent W Smith: RSCDS XXXVI 3 · Crib: MiniCribbs · Diagram: Keith Rose's Diagrams

- 1-8** 1s set, cast 1 place & dance round 1st corners passing corners LSh  
**9-16** 1s dance reels of 3 across (1st Man with 2s & 1st Lady with 3s), 1s turn LH to face 1st corners  
**17-18** Centre dancers change with 1st corners RH **while** 2nd corners set  
**19-20** 1st corners (in centre) change places LH **while** new 1st & 2nd corners dance clockwise round to next corner place  
**21-24** Repeat the Fig in bars 17-20 from new places  
**25-32** Repeat 17-20 from new places, 1s end by turning LH to 2nd place on opposite sides, 2s+1s+3s set on sides & 1s cross back RH

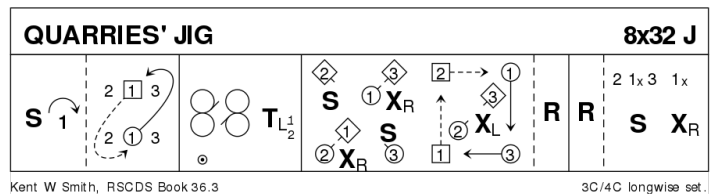

## 17 THE DREAM CATCHER S96 · 4S

Eileen Orr: RSCDS XLV 9 · Crib: MiniCribs · Diagram: Keith Rose's Diagrams

- 1-8** All circle 8H round & back  
**9-16** 1s+3s dance the Swirl: Turn partner RH into Allemande hold & dance LSh round other couple 1/2 way, dance LH across & swirl to face side couples (BtoB with ptnr & Lady facing Man)  
**17-24** All dance reels of 4 across  
**25-32** All set & dancing couples dance out between side couples, cross & cast to change places RH with partner back into places  
**33-40** All set & advance with partners, retire diagonally with corners & set  
**41-48** 1L+4M dance R&L with 3L+2M (on diagonal)  
**49-56** 1M+2L dance R&L with 3M+4L (other diagonal)  
**57-64** All set with corners, Adv+Ret with partners & set  
**65-88** 2s & 4s repeat bars 9-32  
**89-96** All circle 8H round & back

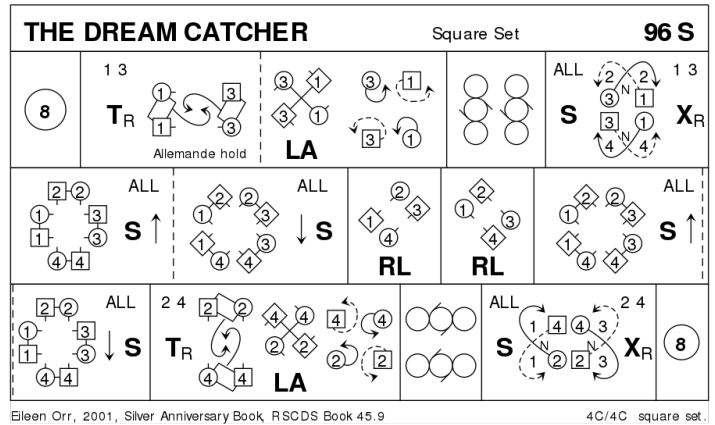

## 18 GOTHENBURG'S WELCOME J32 · 3/4L

Bobby Munro: RSCDS XXXVII 3 · Crib: MiniCribs · Diagram: Keith Rose's Diagrams

- 1-4** 1s cast 1 place & set advancing to 1st corner  
**5-16** 1s Dance to Each Corner & Set:  
**5-6** 1s change places with 1st corners passing RSh & 1st corners pass RSh with a 1/4 turn to right in centre to face 2nd corners (as 2nd corners set),  
**7-8** Original 1st cnrns change places with 2nd cnrns passing RSh & 2nd cnrns pass RSh with a 1/4 turn to right to face 1s in 3rd cnrn (pstn) as 1s set  
**9-10** Original 2nd corners change places with 1s passing RSh & 1s pass RSh with a 1/4 turn to right to face 2nd corner (pstn) as orig 1st corners set  
**11-16** Repeat this Fig once more until 1s end in centre facing 3rd corner positions with 3s & 2s in 1st & 3rd places opposite sides  
**17-24** 1s dance 1/2 diagonal Reel of 4 with 3rd corner & 1/2 diagonal Reel with 4th corners  
**25-32** 1s dance RH hands across (L with 2s & M with 3s) & 2s+1s+3s turn RH

