

ZA 2017-06-23 RSCDS Cape Town No Walk No Talk Evening VI

1 PELORUS JACK J32 · 3/4L

Barry Skelton: RSCDS XLI 1 · Crib: MiniCribs

- 1-8 1s cross RH & cast 1 place, dance RH across with 3s & 1s end with Man facing his 1st corner with his partner behind him
- 9-16 1s dance Alternating Tandem 1/2 reel of 3 with 1st corners, 1s dance Alternating Tandem 1/2 reel with 2nd corners
- 17-24 1s dance Alternating Tandem 1/2 reels of 3 with Ladies 1st corner (pstrn), 1s dance Alternating Tandem 1/2 reel with Ladies 2nd corner (pstrn)
- 25-32 1M followed by partner dance into LH across with 2s, 1s retain LH & 1/2 turn to own sides & 2s+1s+3s set

2 J. B. MILNE R32 · 3/4L

Hugh Foss: A Guide to Scottish Country Dancing (ex-Collins) · Crib: MiniCribs

- 1-8 1M+2L set advancing & turn RH, 1L+2M set advancing & turn RH
- 9-16 1s set to each other & turn 2H, cast to 2nd place & Petronella turn to Lady between 2s & Man between 3s
- 17-24 1s set & 3/4 turn RH **while** 2s+3s change places RH on sides & set, 1s repeat but 2s & 3s cross RH & set
- 25-32 1s set & change places RH **while** 2s+3s change places RH on sides & set, 1s cast round corner to 2nd pl own sides as 2s+3s cross RH & all set

3 12 COATES CRESCENT S32 · 4/4L

RSCDS: RSCDS XL 5 · Crib: MiniCribs

- 1-8 All set on sides & cross RH, all set & cross back RH
- 9-16 1s dance down to meet 4s who dance up & 1L+4L also 1M+4M dance out own sides, cast back to places & 1s lead down to 4th place
- 17-24 3s+4s dance R&L
- 25-32 2s+3s also 4s+1s dance RH across & LH back

4 BEST SET IN THE HALL J32 · 3/4L

Helen Greenwood: RSCDS XLVI 7 · Crib: MiniCribs

- 1-8 1s set & 1L followed by partner casts below 3s. 1L crosses & casts up to face her 1st corner **while** 1M dances up the middle to face 1st corner
- 9-12 1s set to 1st corners & dance RSh round each other into 3rd corner (pstn) **while** 1st corners dance in & turn right about to face their original position
- 13-16 1s+1st crnr person set & 1st crnr persons dance RSh round each other into diag opp crnrs **while** 1s dance in & pivot to right to face 2nd crnrs
- 17-24 1s repeat bars 9-16 with 2nd corners & end passing RSh to 2nd place opposite sides. (3)(1)(2)
- 25-32 2s+1s+3s chase clockwise 1/2 way & turn partners RH

5 NEVER AT SEA R48 · 6/6L

J C Haddow · Crib: MiniCribs

4s & 5s & 6s start on opp sides

- 1-8 1s cross RH & cast to 2nd place, cross LH & cast to 3rd place **while** 6s cross RH & cast to 5th place, cross LH & cast to 4th place
- 9-16 1M+6L Prom hold dance reel of 3 with 4s (pass 4M LSh to start) **while** 6M+1L dance reel of 3 with 3s (pass 3M LSh) end 1s in 3rd place side by side facing up & 6s in 4th place facing down ready for:..
- 17-24 1s & 6s dance reflection reels on sides dancing up/down between 3s/4s to start
- 25-32 1s+6s dance R&L ending with 1s facing up & 6s facing down
- 33-36 End couples cross RH **while** cpl in 2nd+3rd pl also cpl in 4th+5th pl dance 1/2 RH across & all (1st+2nd pl, 3rd+4th pl, 5th+6th pl) change pl LH on side
- 37-40 Repeat bars 33-36
- 40-44 Repeat bars 33-36
- 45-48 All turn partners RH 5 4 6(1)(3)(2)

Dance 3 times to end 6 5 4(3)(2)(1) or 6 times to end 1 2 3(4)(5)(6)

6 THE ROAD TO MCGREGOR S32 · 4/4L

Andrew Hodgson · Crib: MiniCribs

- 1-8 1s & 3s dance down NHJ, turn 2H, dance up NHJ, turn 2H to end in original places facing out
- 9-16 Reels of 4 on sides, 1s & 3s out/down, 2s & 4s in/up to start
- 17-24 1s+2s also 3s+4s Set&Link. 1s & 3s petronella turn & set
- 25-32 1s+3s dance 1/2 reel of 4 up/down centre. 3s & 1s turn partners 3/4 RH to end in 2nd/4th place own sides. 2s+3s+4s+1s set.

7 QUARRIES' JIG J32 · 3/4L

*Kent W Smith: RSCDS XXXVI 3 · Crib: MiniCrib*s

- 1-8 1s set, cast 1 place & dance round 1st corners passing corners LSh
- 9-16 1s dance reels of 3 across (1st Man with 2s & 1st Lady with 3s), 1s turn LH to face 1st corners
- 17-18 Centre dancers change with 1st corners RH **while** 2nd corners set
- 19-20 1st corners (in centre) change places LH **while** new 1st & 2nd corners dance clockwise round to next corner place
- 21-24 Repeat the Fig in bars 17-20 from new places
- 25-32 Repeat 17-20 from new places, 1s end by turning LH to 2nd place on opposite sides, 2s+1s+3s set on sides & 1s cross back RH

8 MISS JOHNSTONE OF ARDROSSAN R32 · 5/5L

*Roy Goldring: 14 Social Dances for 2000 · Crib: MiniCrib*s

- 1-8 1s set & cast 1 place, 1s followed by 3s dance up & cast - 1s to 3rd place & 3s to 2nd place
- 9-16 1s cross down & dance reflection reels of 3 with 4s+5s on opposite sides - 1s end in 3rd place opposite sides
- 17-24 1s cross up & dance reflection reels of 3 on own sides with 2s+3s - 1s ending in 3rd place own sides
- 25-32 1s set & cast down 1 place, 1s followed by 5s dance up between 4s & cast - 1s to 5th place & 5s to 4th place

9 CHERRYBANK GARDENS S32 · 3/3L

*John Drewry: Bankhead Book Part 1 · Crib: MiniCrib*s

- 1-8 1s+2s set & Petronella-in-tandem twice to end with 2s+1s on opposite sides having changed places
- 9-16 2s+1s set & 2s cross RH & 1s LH, 1L dances RH across with 2s & 1M with 3s
- 17-24 1s+3s Set+Link & circle 4H round to left
- 25-32 2s+3s+1s dance Grand Chain (2s crossing to commence)

10 THE WATERNISH TANGLE J32 · 3/4L

*Andrea Barfoot: The Skye Collection Vol 2 · Crib: MiniCrib*s

- 1-8 1s cross down RH, set, cross down LH & set
- 9-16 1s cross RH, change places on sides with 3s LH, 2s+1s cross RH & 3/4 turn LH on sides to form line of 4 across
- 17-24 2s+1s dance the Targe :
 - 17-18 1st & 2nd Ladies 3/4 turn RH **while** Men dance 1/4 way round anticlockwise
 - 19-20 1st Man with 2nd Lady & 1st Lady with 2nd Man full turn LH
 - 21-22 1st & 2nd Ladies 3/4 turn RH **while** Men dance 1/4 way round anticlockwise
 - 23-24 1st Man with 2nd Lady & 1st Lady with 2nd Man turn LH to end on sides to 2(1)3
- 25-32 1s cross down below 3s, cast up, dance up between 2s & cast to 2nd place

11 SANDS OF MORAR S32 · 3/4L

Barry Priddey: RSCDS XLV 6 · Crib: MiniCribs

- 1-8 1s dance Fig of 8 round 2s giving hands when possible
- 9-16 1s dance reflection reels of 3 on own sides (1s dance down between 2s to begin)
- 17-24 1s turn 2H & dance down middle to 3rd pl as 2s+3s continue reel & dance down behind 1s, all set & 1s followed by 2s+3s cast up to orig pls
- 25-32 1s+2s dance the Tourbillon :
1s & 2s turn partners 2H 1/2 way, 1M & 2L lead partners on 1 place clockwise to end 1s on Ladies side & 2s on Men's side, 1s set to 2s
1s & 2s 1/2 turn partners 2H, 1L & 2M lead partners on 1 place to end 2s in 1st pl & 1s in 2nd pl & 2s+1s cross RH to own sides

12 THE REEL OF THE 51ST DIVISION R32 · 3/4L

James Edward McCartney Atkinson: RSCDS XIII 10 · Crib: MiniCribs

- 1-8 1s set & cast below 3s, lead up to face 1st corners
- 9-16 1s set & turn 1st corners RH to balance in diagonal line, set & 1s turn LH to face 2nd corners
- 17-24 1s set & turn 2nd corners RH to Bal-in-Line, set & 1s turn LH to 2nd place own sides
- 25-32 2s+1s+3s circle 6H round & back

Extras

13 THE BYRON STRATHSPEY S32 · 3/3L

John Drewry: Deeside Book Part 2 · Crib: MiniCribs

- 1-8 All petronella turn into the centre & set to partner, turn 2H 1.1/4 times back to places
- 9-16 1s+2L & 3s+2M dance RH across, 2s pass RSh & dance LH across with other couple
- 17-24 2s in prom hold dance reel of 3 with 1s passing 1L RSh, end 2s in centre at top
- 25-32 2s+1s+3s dance Allemande

14 THE PIPER AND THE PENGUIN R88 · 4S

Roy Goldring: The Scotia Suite of Scottish Country Dances · Crib: MiniCribs

- 1-8 Ladies dance RSh round their corners, dance RH across ending in centre
- 9-16 Ladies dance LSh round their partners, dance LH across & back to places
- 17-24 Men dance RSh round their partners, dance RH across ending in centre
- 25-32 Men dance LSh round corners, dance LH across & back to places
- 33-40 1s & 3s turn partners RH 1.1/4 times, Men followed by partners dance out between side couples & back to places (1M thru 4s & 3M thru 2s)
- 41-48 1s+3s dance R&L
- 49-64 2s+4s repeat bars 33-48
- 65-72 Ladies dance in turning right about to dance out, cast clockwise to opposite Lady's place
- 73-80 Men dance in turning left about to dance out, cast anticlockwise to opposite places
- 81-88 All turn partners RH 1.1/4 times into prom hold, Promenade anticlockwise 1/2 way round to original places

15 THE GENTLEMAN S32 · 3/4L

Roz Scott Huxley: RSCDS XXXV 5 · Crib: MiniCribs

- 1-8** 1s turn 2H & remain in middle facing each other as 2s step up, 1s+2s set (1s advancing & pass LSh to face opposite partner) & dance 1/2 reel of 4 across with 2s with 1s ending reel giving LH to face down on own side between 2s
- 9-16** 1s dance down to end between 3s & face each other, 1s+3s set (1s advancing & pass LSh to face opposite partner) & 1/2 reel of 4 across with 3s 1s end giving LH to face up on own side between 3s
- 17-24** 1s lead up to top, cross over & cast to 2nd place & 1/2 reels of 3 across (L with 2s & M with 3s)
- 25-32** 2s+1s dance Diamond Poussette

16 THE HIGHLAND FAIR J32 · 2/4L

RSCDS Graded 6 · Crib: MiniCribs

- 1-8** 1s cast, dance down behind own lines, turn outwards & dance back to place
- 9-16** 1s+2s turn partners RH back to place & then turn LH
- 17-24** 1s followed by 2s, lead down the middle & 2s lead back to the top
- 25-32** 2s+1s dance R&L

ZA 2017-06-23 RSCDS Cape Town No Walk No Talk Evening VI

1 PELORUS JACK 8x32 J

1x3 2 1 3 2 1 3

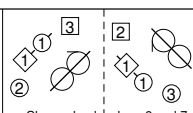
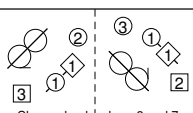
$X_R \curvearrowright 1 RA$   $2 1x \quad 2 1 3$

$LA \quad T_{L1} \quad S$

Change lead on bars 3 and 7 Change lead on bars 3 and 7

Barry Skelton, 1993, Dolphin Book, RSCDS Book 41.1 3C/4C longwise set.

2 J. B. MILNE 8x32 R

$S \uparrow T_R$ $S \uparrow T_R$ $S \uparrow T_B \curvearrowright T_\diamond$ $ST_{R3} \quad X_R S$

$1x \quad 3 2$ $1 \quad 3 \quad 2$ $2 1 3$

$ST_{R3} \quad X_R S$ $S X_R \quad X_R S$ $X_R \quad S$

Hugh Foss, 1954, Angus Fitchet S D Album 3C/4C longwise set.

3 12 COATES CRESCENT 4x32 S

1 2 3 4 1 2 3 4 1 3 3 4 2 3 4 1

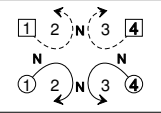
$S X_R S X_R$  $1 \quad 3$ RL $RA LA$

RSCDS, 1998, RSCDS Book 40.5 4C/4C longwise set.

4 BEST SET IN THE HALL 8x32 J

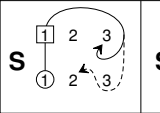
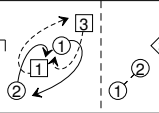
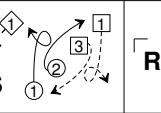
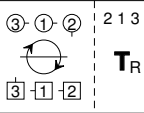
S  S  S  R  T_R

Helen Greenwood, 2003, RSCDS Book 46.7 3C/4C longwise set.

5 NEVER AT SEA 4C 5C & 6C start on opposite side 6x48 R

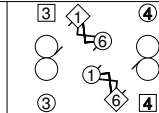
1: $X_R \curvearrowright 1 X_L \curvearrowright 1$  $2 3 1 \quad 6x 4x 5x$ $1 6x$

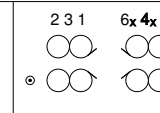
6x: $X_R \curvearrowright 1 X_L \curvearrowright 1$  $2 3 1 \quad 6x 4x 5x$ RL

$2 \quad 3 1 \quad 6x 4x \quad 5x$ $2-1 \quad 3-4 \quad 6-5$ $2-1 \quad 3-4 \quad 6-5$ $R \quad R \quad T_R$

J Haddow, SCD A'hm askin'. 6C/6C longwise set.

6 THE ROAD TO MCGREGOR 4x32 S

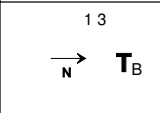
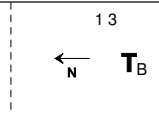
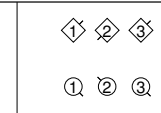
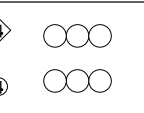
1 3 1 3  T_B  T_B  $1 \quad 2 \quad 3 \quad 4$ 

1 2 3 4 1 3 $1-1 \quad 3-3$ $3 1 \quad 2 3 4 1$

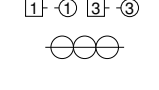
$S \text{ \& LINK}$ $T_\diamond S$  $T_{R3} \quad S$

Andrew Hodgson, 2013 4C/4C longwise set.

7 QUARRIES' JIG 8x32 J

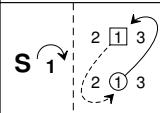
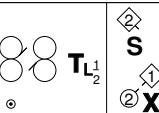
$S \curvearrowright 1$  T_{L1}  $S \quad X_R$ $2 \quad X_L \downarrow$ $R \quad R$ $2 1x 3 \quad 1x$

Kent W Smith, RSCDS Book 36.3 3C/4C longwise set.

8 MISS JOHNSTONE OF ARDROSSAN 5 Couples 5x32 R

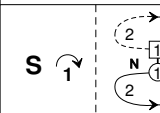
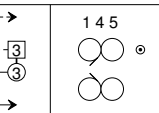
$S \curvearrowright 1$  $1 4 5$ $2 3 1x$ $S \curvearrowright 1$ 

Roy Goldring, 2000, 14 Social Dances for 2000 5C/5C longwise set.

9 CHERRYBANK GARDENS 3 Couple Set 3x32 S

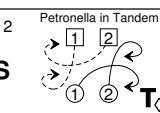
1 2 Petronella in Tandem  R $2x 1x \quad 2x \quad 1x$ $2 \quad 1 \quad 1 \quad 3$

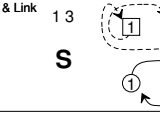
S  R $S \quad X_R \quad X_L$ $RA \quad RA$

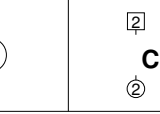
Set & Link 1 3  3 1  $2 \quad 3 \quad -1$

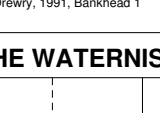
S  4 **CHAIN** $2 \quad 3 \quad -1$

John Drewry, 1991, Bankhead 1 3C/3C longwise set.

10 THE WATERNISH TANGLE 8x32 J

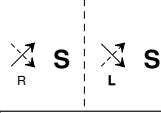
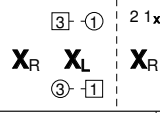
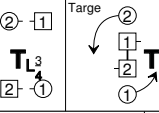
S  S  $X_R \quad X_L$ $2 1x \quad 2-1$ $X_R \quad T_{L3}$  $2-1 \quad 1 \quad 2-1$

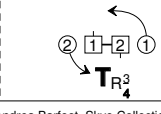
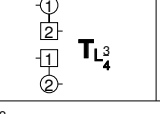
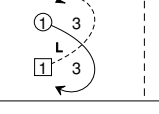
T_{R3}  T_{L3}  T_L 

Andrea Barfoot, Skye Collection 2 3C/4C longwise set.

11 SANDS OF MORAR 8x32 S

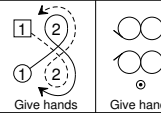
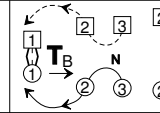
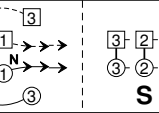
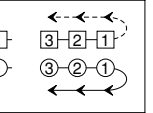
  T_B  S 

Give hands Give hands

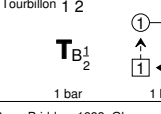
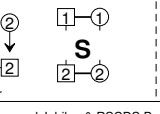
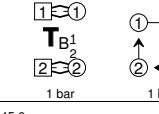
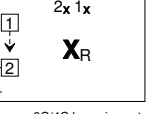
Tourbillon 1 2 T_{B1}^2  S  T_{B1}^2  $2x 1x$ X_R 

1 bar 1 bar 1 bar 1 bar

Barry Priddy, 1983, Glasgow Diamond Jubilee & RSCDS Book 45.6 3C/4C longwise set.

12 THE REEL OF THE 51st DIVISION 8x32 R

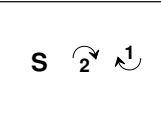
S  $S \quad T_R \quad B \quad T_{L1}$ $S \quad T_R \quad B \quad T_L$ $2 1 3$

6

Jimmy Atkinson & Peter Oliver, 1940, RSCDS Book 13.10 3C/4C longwise set.

13 THE BYRON STRATHSPEY 3 Couples 3x32 S

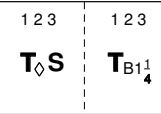
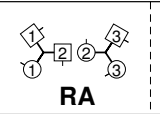
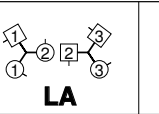
1 2 3 1 2 3 $T_\diamond S$ T_{B1}  RA  LA  1 $2 1 3$

A

John Drewry, 1975, Deeside Book 2 3C/3C longwise set.

14 THE PIPER AND THE PENGUIN Square Set 88 R

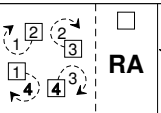
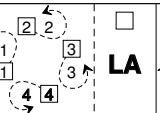
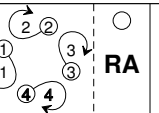
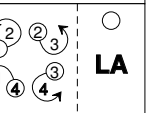
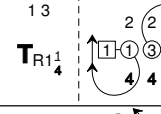
T_{R1}  RL  R  16 bars  $Chase$ 

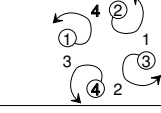
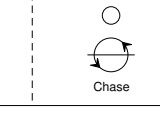
T_{R1}  $Chase$  **ALL** T_{R1} **PROM** anticlockwise

Roy Goldring, 2002, Scotia Suite 4C/4C square set.

ZA 2017-06-23 RSCDS Cape Town No Walk No Talk Evening VI

15

| THE GENTLEMAN | | | | 8x32 S | | | |
|---|--|--------------------|--|---|--|--------------------|--|
| <p>T_B</p> | | <p>S↑ S</p> | | <p>T_L¹₂</p> | | <p>S↑ S</p> | |
| <p>T_L¹₂</p> | | <p>P</p> | | <p>T_L¹₂</p> | | <p>P</p> | |

Roz Scott Huxley, 1986, RSCDS Book 35.5 3C/4C longwise set.

16

| THE HIGHLAND FAIR | | | 8x32 J | | |
|---|--|---|--------|--------------------|--|
| <p>T_B</p> | | <p>T_L¹₂</p> | | <p>S↑ S</p> | |
| <p>T_L¹₂</p> | | <p>P</p> | | <p>P</p> | |

RSCDS Graded Book 1.6 2C/4C longwise set.