

ZA 2015-11-06 RSCDS Cape Town No Walk No Talk Evening II

1 THE HIGHLAND FAIR J32 · 2/4L

RSCDS Graded 6 · Crib: MiniCribs · Diagram: Keith Rose's Diagrams

- 1-8 1s cast, dance down behind own lines, turn outwards & dance back to place
- 9-16 1s+2s turn partners RH back to place & then turn LH
- 17-24 1s followed by 2s, lead down the middle & 2s lead back to the top
- 25-32 2s+1s dance R&L

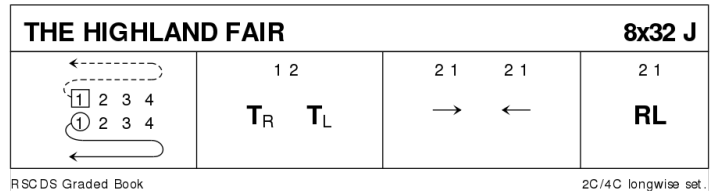

2 SHIFTIN' BOBBINS R32 · 3/4L

Roy Clowes: A Guide to Scottish Country Dancing · Crib: MiniCribs · Diagram: Keith Rose's Diagrams

- 1-8 1s cross RH to double triangle position with 2s+3s & set, 1s cast up to top & dance down until they are between 2s & 3s
- 9-16 1L dances RH across with 2M+3M **while** 1M dances LH across with 2L+3L, 1s followed by 2s+3s dance down centre
- 17-24 3s followed by 2s+1s dance up & 3s+2s cast down to places, 1L dances LH across with 2M+3M **while** 1M dances RH across with 2L+3L
- 25-32 1s dance up to top & cast down to 2nd place opposite side, 1s dance 1/2 Fig of 8 around 2s to end in 2nd place on own sides

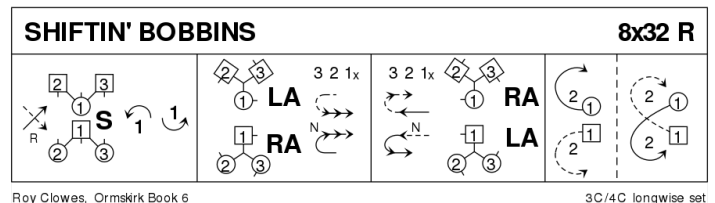

3 SUGAR CANDIE S32 · 3/4L

RSCDS XXVI 9 · Crib: MiniCribs · Diagram: Keith Rose's Diagrams

- 1-8 1s set & cast 1 place, cross passing LSh & cast RSh round their 1st corner into centre ending BtoB (Lady facing up, Man down)
- 9-16 1L circle left with 2s & 1M with 3s, turn to face partner & set, 3/4 turn partner 2H to end facing 1st corners
- 17-24 1s turn 1st corner RH, partner LH, 2nd corner RH, partner LH & end facing 1st corners
- 25-32 1s dance Reel of 3 on opposite sides passing 1st corner LSh & cross RH to 2nd place own sides

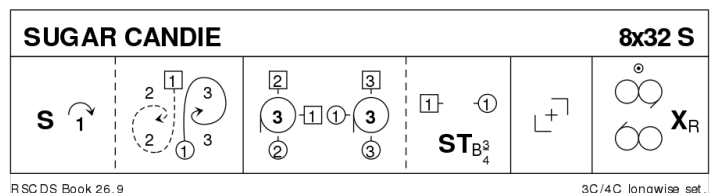

4 BEST SET IN THE HALL J32 · 3/4L

Helen Greenwood: RSCDS XLVI 7 · Crib: MiniCribbs · Diagram: Keith Rose's Diagrams

- 1-8** 1s set & 1L followed by partner casts below 3s, 1L crosses & casts up to face her 1st corner **while** 1M dances up the middle to face 1st corner
- 9-12** 1s set to 1st corners & dance RSh round each other into 3rd corner (pstn) **while** 1st corners dance in & turn right about to face their original position
- 13-16** 1s+1st crnr person set & 1st crnr persons dance RSh round each other into diag opp cnrns **while** 1s dance in & pivot to right to face 2nd crnrns
- 17-24** 1s repeat bars 9-16 with 2nd corners & end passing RSh to 2nd place opposite sides. (3)(1)(2)
- 25-32** 2s+1s+3s chase clockwise 1/2 way & turn partners RH

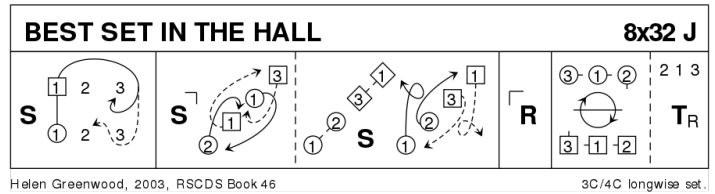

5 CITY OF STIRLING REEL R32 · 3/4L

Roy Goldring: Bannockburn 700 · Crib: MiniCribbs · Diagram: Keith Rose's Diagrams

- 1-8** 1s+2s+3s dance Snowball Grand Chain (1s+2s change places on sides to start). (3)(1)(2)
- 9-16** 1s cross (pass RSh) & 1/2 turn RH person in 3rd corner, 1s followed by corners change places (diag) passing LSh & 1s cast to 2nd place (opp sides) as corners end in original places
- 17-24** 1s cross (pass LSh) & 1/2 turn LH person in 4th corner, 1s followed by corners change places (diag) passing RSh & 1s cast to 2nd place (opp sides) as corners end in original places. 2(1)3
- 25-32** All turn RH (4 bars) & 1s dance 1/2 Figs of 8 (Lady up & Man down)

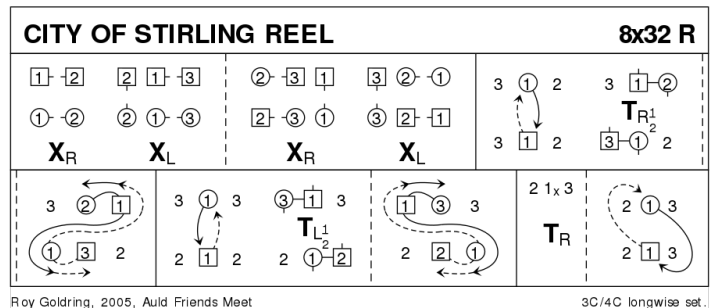

6 THE MINISTER ON THE LOCH S32 · 3/3L

Roy Goldring: Magazine Dances 2005-2009 · Crib: MiniCribbs · Diagram: Keith Rose's Diagrams

- 1-8** 1s+2s dance Diamond Poussette
- 9-16** 1s dance down for 2 steps, turn 2H, dance up to top & turn 2H
- 17-24** 1s+3s dance double Fig of 8 round 2s with 1s casting to start
- 25-32** 1M+2M turn LH 1.1/2 times **while** 1L+2L turn RH 1.1/2 times, 1M+3M turn RH 1.1/2 times **while** 1L+3L turn LH 1.1/2 times

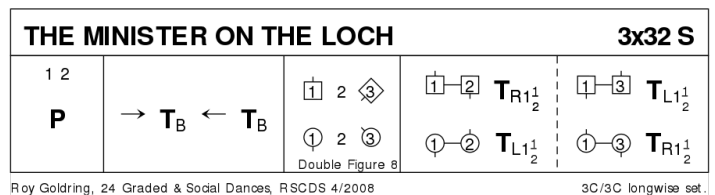

7 THE CRANBERRY TART J32 · 3/4L

Terry Glasspool: Dances from the Seven Year Itch · Crib: MiniCribs · Diagram: Keith Rose's Diagrams

- 1-8** 1M sets & casts 1 place, sets & petronella turns between 3s facing up **while** 1L stands for 2 bars then sets, casts 1 place & sets
- 9-16** 1M sets in line with 3s & all 3 Adv+Ret then 1M advances to partner **while** 1L petronella turns between 2s & sets in line with 2s then all 3 Adv+Ret
- 17-24** 1L followed by partner dances reel of 3 across with 2s (RSh to 2L) to end in 2nd place own sides
- 25-32** 1s dance RSh reels of 3 on sides giving RSh to 3s

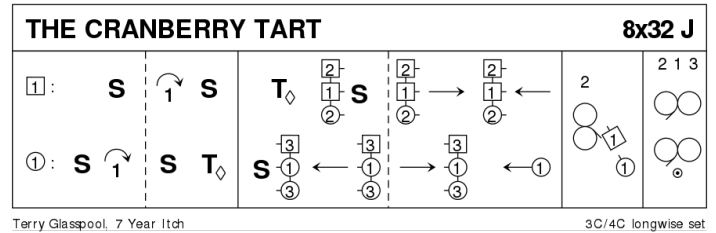

8 NEVER AT SEA R48 · 6/6L

J C Haddow · Crib: MiniCribs · Diagram: Keith Rose's Diagrams

4s & 5s & 6s start on opp sides

- 1-8** 1s cross RH & cast to 2nd place, cross LH & cast to 3rd place **while** 6s cross RH & cast to 5th place, cross LH & cast to 4th place
- 9-16** 1M+6L Prom hold dance reel of 3 with 4s (pass 4M LSh to start) **while** 6M+1L dance reel of 3 with 3s (pass 3M LSh) end 1s in 3rd place side by side facing up & 6s in 4th place facing down ready for:..
- 17-24** 1s & 6s dance reflection reels on sides dancing up/down between 3s/4s to start
- 25-32** 1s+6s dance R&L ending with 1s facing up & 6s facing down
- 33-36** End couples cross RH **while** cple in 2nd+3rd pl also cple in 4th+5th pl dance 1/2 RH across & all (1st+2ndpl, 3rd+4thpl, 5th+6thpl) change pl LH on side
- 37-40** Repeat bars 33-36
- 40-44** Repeat bars 33-36
- 45-48** All turn partners RH 5 4 6(1)(3)(2)

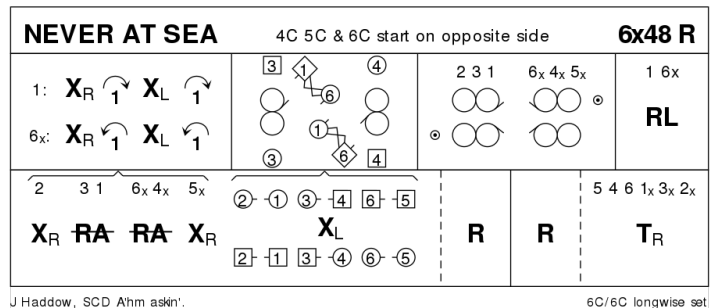

Dance 3 times to end 6 5 4(3)(2)(1) or 6 times to end 1 2 3(4)(5)(6)

9 THE BYRON STRATHSPEY S32 · 3/3L

John Drewry: Deeside Book Part 2 · Crib: MiniCribs · Diagram: Keith Rose's Diagrams

- 1-8** All petronella turn into the centre & set to partner, turn 2H 1.1/4 times back to places
- 9-16** 1s+2L & 3s+2M dance RH across, 2s pass RSh & dance LH across with other couple
- 17-24** 2s in prom hold dance reel of 3 with 1s passing 1L RSh, end 2s in centre at top
- 25-32** 2s+1s+3s dance Allemande

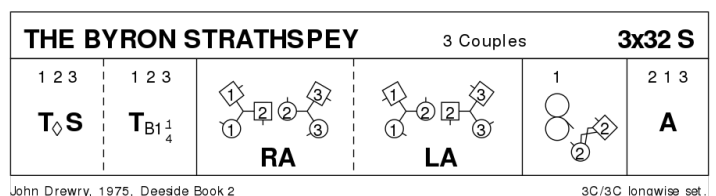

10 THE DEIL AMANG THE TAILORS

R32 · 3/4L

RSCDS XIV 7 · Crib: MiniCribs · Diagram: Keith Rose's Diagrams

- 1-8** 1s+2s set & dance RH across 1/2 way, set & dance LH across 1/2 way back to place
- 9-16** 1s lead down the middle & back to top
- 17-24** 1s+2s dance Allemande
- 25-32** 2s+1s+3s circle 6H round & back

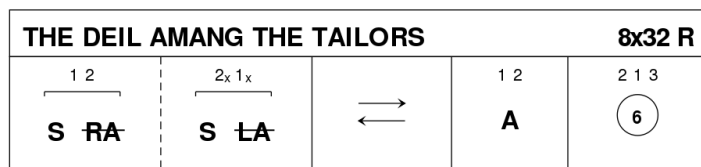

Daves Collection, RSCDS Book 14

3C/4C longwise set.

11 JOIE DE VIVRE J32 · 3/4L

Irene van Maarseveen: RSCDS XXXIX 2 · Crib: MiniCribs · Diagram: Keith Rose's Diagrams

- 1-8** 1s set, cast 1 place, 1s dance down between 3s & cast back to 2nd place on own sides
- 9-16** 2s+1s+3s turn RH & chase 1/2 way round clockwise
- 17-24** 3s+1s+2s dance DoSiDo, set & 1/2 turn partners RH for Allemande
- 25-32** 3s+1s+2s dance Allemande

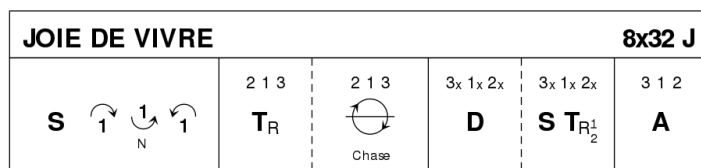

Irene van Maarseveen, 1996, RSCDS Book 39

3C/4C longwise set.

12 THE MONTGOMERIES' RANT

R32 · 3/4L

Castle Menzies (18C): RSCDS X 1 · Crib: MiniCribs · Diagram: Keith Rose's Diagrams

- 1-8** 1s cross RH & cast down to 2nd place, cross LH & 1L casts up **while** 1M casts down
- 9-16** 1s dance reels of 3 across, 1L with 2s & 1M with 3s
- 17-24** 1s with nearer hands joined (Lady on Mans left) set to 2L & turn inwards to set to 3M, set to 3L & turn inward & set to 2M
- 25-32** 2s+1s+3s dance reels of 3 on opposite sides 1s giving RSh to 2nd corner, 1s cross RH to 2nd place own sides

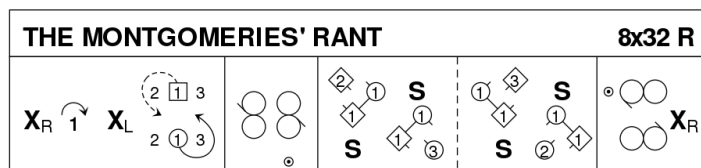

Castle Menzies, 1749, RSCDS Book 10

3C/4C longwise set.

13 THE DREAM CATCHER S96 · 4S

Eileen Orr: RSCDS XLV 9 · Crib: MiniCribs · Diagram: Keith Rose's Diagrams

- 1-8** All circle 8H round & back
- 9-16** 1s+3s dance the Swirl: Turn partner RH into Allemande hold & dance LSh round other couple 1/2 way, dance LH across & swirl to face side couples (BtoB with ptr & Lady facing Man)
- 17-24** All dance reels of 4 across
- 25-32** All set & dancing couples dance out between side couples, cross & cast to change places RH with partner back into places
- 33-40** All set & advance with partners, retire diagonally with corners & set
- 41-48** 1L+4M dance R&L with 3L+2M (on diagonal)
- 49-56** 1M+2L dance R&L with 3M+4L (other diagonal)
- 57-64** All set with corners, Adv+Ret with partners & set
- 65-88** 2s & 4s repeat bars 9-32
- 89-96** All circle 8H round & back

