

ZA 2016-03-14 St Patrick's Day Class

1 MULLIGAN STEW R32 · 3/4L

Deanna Saint Amand: Let's All Dance Too · Crib: SCDDDB Contributed Cribs & Diagrams

- 1- 1c+2c RH across & LH back
- 9- 1c lead down the middle and up
- 17- 1c cast off (2c up on 3-4); 1c dance down below 3c | cast up to 2pl
- 25-32 2c+1c Rights & Lefts

2 THE LUCKENBOOTH BROOCH J32 · 3/4L

John Bowie Dickson: Reels and Wheels (CD booklet) · Crib: MiniCribs · Diagram: Keith Rose's Diagrams

- 1-8 1s in prom hold (Lady on Man's left) dance reel of 3 with 2s (RSh to 2M) & end facing 3M
- 9-16 1s dance reel with 3s (RSh to 3M) ending with 1s dancing across to Men's side
- 17-24 1M casts up & 1L dn into centre & dance out Ladies side, 1M cast up & 1L dn to end 1M b'tw'n 2s facing dn & 1L+3s face up as 2s+3s dance R&L
- 25-32 2s+1s+3s set twice, 1s turn RH 1.3/4 times to 2nd places

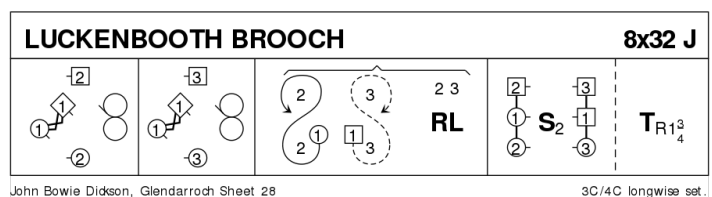

3 THE MINISTER ON THE LOCH S32 · 3/3L

Roy Goldring: Magazine Dances 2005-2009 · Crib: MiniCribs · Diagram: Keith Rose's Diagrams

- 1-8 1s+2s dance Diamond Poussette
- 9-16 1s dance down for 2 steps, turn 2H, dance up to top & turn 2H
- 17-24 1s+3s dance double Fig of 8 round 2s with 1s casting to start
- 25-32 1M+2M turn LH 1.1/2 times **while** 1L+2L turn RH 1.1/2 times, 1M+3M turn RH 1.1/2 times **while** 1L+3L turn LH 1.1/2 times

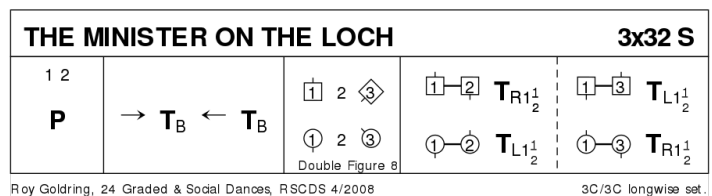

4 THE LEPRECHAUN J32 · 3/4L

Iain Boyd: All Kinds Of Everything · Crib: MiniCribs

- 1-8 1s set, cross RH, set & cast into middle facing 2s
- 9-16 2s+1s set, turn other partner (1s dancing out), 1s dance down between 3s & cast up into middle to face 3s
- 17-24 1s+3s set, turn other partner (1s dancing out), 1s dance up between 2s & cast to 2nd place opposite sides
- 25-32 1s dance reels of 3 on sides (dancing down between 3s to start) & cross RH to 2nd place own sides

5 KILKENNY CASTLE S32 · 3/4L

Bill Forbes: *Craigievar Book 2* · Crib: *MiniCribs* · Diagram: *Keith Rose's Diagrams*

- 1-8** 1s+2s set, 1s cross RH & cast 1 place, 1s dance in to meet partner & face down, 1s turn 3s with nearer hand to face up
- 9-16** 1s dance reflection reels of 3 on sides (1s dancing in & up between 2s to start)
- 17-24** 1s petronella turn to middle as 2L+3L & 2M+3M change pl RH, set in lines across, 1s petronella turn to sides as 2s+3s cross RH & set on sides
- 25-32** 1s dance Diag R&L (1M crossing down & 1L crossing up)

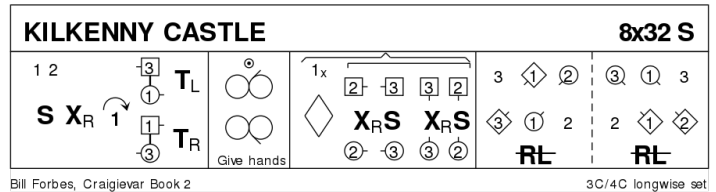

6 THE FIRST RAIN OF SPRING J32 · 3/3L

Wouter Joubert: *RSCDS XLIX 4* · Crib: *MiniCribs* · Diagram: *Keith Rose's Diagrams*

- 1-8** 1s dance down, cast up round 3s, meet, dance up to 1st place facing out. 1s+2s 1/2 turn (Men LH, Ladies RH)
- 9-16** 2s+1s dance double Figs 8 (1s cross up, 2s cast to start)
- 17-20** 1s+3s 3/4 turn RH into line up/down in middle facing partner & set
- 21-28** 1s+3s dance 1/2 Celtic Reel:
21-22 1s+3s pass partner RSh
23-24 1M+3L dance clockwise **while**
 1L+3M dance 3/4 round each other LSh to face partners in line across
25-26 1s+3s pass partner RSh
27-28 1L+3M dance clockwise **while** 1M+3L dance 3/4 round each other LSh to face partners in line up/down set
- 29-32** 3s+1s 3/4 turn partners RH to sidelines & 2s+3s+1s set

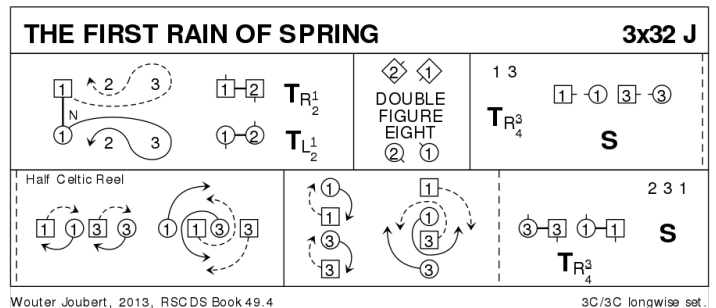

7 NEVER AT SEA R48 · 6/6L

J C Haddow · Crib: MiniCribs · Diagram: Keith Rose's Diagrams

4s & 5s & 6s start on opp sides

- 1-8** 1s cross RH & cast to 2nd place, cross LH & cast to 3rd place **while** 6s cross RH & cast to 5th place, cross LH & cast to 4th place
- 9-16** 1M+6L Prom hold dance reel of 3 with 4s (pass 4M LSh to start) **while** 6M+1L dance reel of 3 with 3s (pass 3M LSh) end 1s in 3rd place side by side facing up & 6s in 4th place facing down ready for:..
- 17-24** 1s & 6s dance reflection reels on sides dancing up/down between 3s/4s to start
- 25-32** 1s+6s dance R&L ending with 1s facing up & 6s facing down
- 33-36** End couples cross RH **while** cple in 2nd+3rd pl also cple in 4th+5th pl dance 1/2 RH across & all (1st+2ndpl, 3rd+4thpl, 5th+6thpl) change pl LH on side
- 37-40** Repeat bars 33-36
- 40-44** Repeat bars 33-36
- 45-48** All turn partners RH 5 4 6(1)(3)(2)

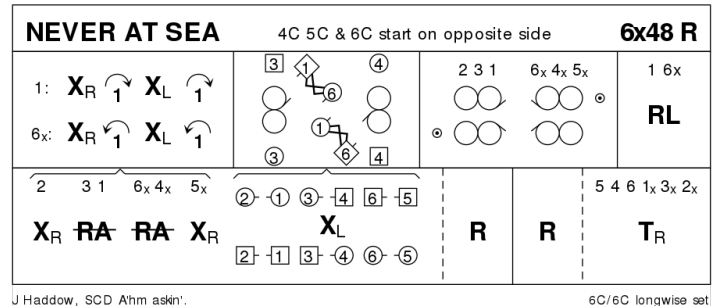

Dance 3 times to end 6 5 4(3)(2)(1) or 6 times to end 1 2 3(4)(5)(6)

REFRESHMENT BREAK

8 PELORUS JACK J32 · 3/4L

Barry Skelton: RSCDS XLI 1 · Crib: MiniCribs · Diagram: Keith Rose's Diagrams

- 1-8** 1s cross RH & cast 1 place, dance RH across with 3s & 1s end with Man facing his 1st corner with his partner behind him
- 9-16** 1s dance Alternating Tandem 1/2 reel of 3 with 1st corners, 1s dance Alternating Tandem 1/2 reel with 2nd corners
- 17-24** 1s dance Alternating Tandem 1/2 reels of 3 with Ladies 1st corner (pstrn), 1s dance Alternating Tandem 1/2 reel with Ladies 2nd corner (pstrn)
- 25-32** 1M followed by partner dance into LH across with 2s, 1s retain LH & 1/2 turn to own sides & 2s+1s+3s set

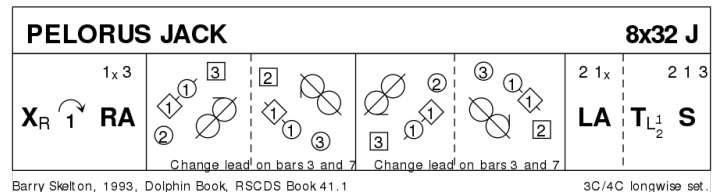

9 THE BYRON STRATHSPEY S32 · 3/3L

John Drewry: Deeside Book Part 2 · Crib: MiniCribbs · Diagram: Keith Rose's Diagrams

- 1-8** All petronella turn into the centre & set to partner, turn 2H 1.1/4 times back to places
- 9-16** 1s+2L & 3s+2M dance RH across, 2s pass RSh & dance LH across with other couple
- 17-24** 2s in prom hold dance reel of 3 with 1s passing 1L RSh, end 2s in centre at top
- 25-32** 2s+1s+3s dance Allemande

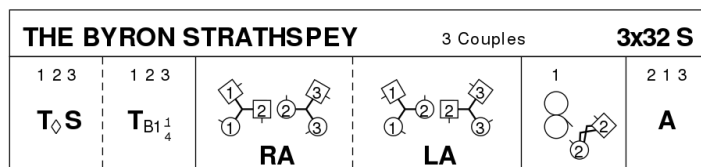

John Drewry, 1975, Deeside Book 2

3C/3C longwise set.

10 BEST SET IN THE HALL J32 · 3/4L

Helen Greenwood: RSCDS XLVI 7 · Crib: MiniCribbs · Diagram: Keith Rose's Diagrams

- 1-8** 1s set & 1L followed by partner casts below 3s, 1L crosses & casts up to face her 1st corner **while** 1M dances up the middle to face 1st corner
- 9-12** 1s set to 1st corners & dance RSh round each other into 3rd corner (pstn) **while** 1st corners dance in & turn right about to face their original position
- 13-16** 1s+1st crnr person set & 1st crnr persons dance RSh round each other into diag opp crnrs **while** 1s dance in & pivot to right to face 2nd crnrs
- 17-24** 1s repeat bars 9-16 with 2nd corners & end passing RSh to 2nd place opposite sides. (3)(1)(2)
- 25-32** 2s+1s+3s chase clockwise 1/2 way & turn partners RH

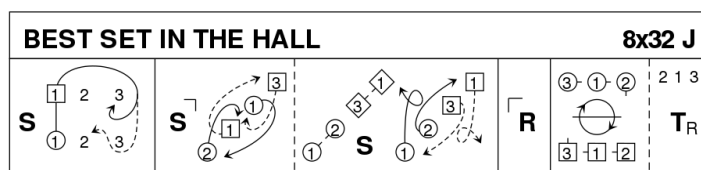

Helen Greenwood, 2003, RSCDS Book 46.7

3C/4C longwise set.

11 LAND OF THE HEATHER HILLS S32 · 4/4L

Barry Priddey: Capercaillie Book · Crib: MiniCribbs · Diagram: Keith Rose's Diagrams

3s & 4s start on opp sides

- 1-8** 1s & 4s set, 1L followed by partner cast to dance Fig of 8 on Ladies side round 2L+3M & end diagonally facing 2M (partner behind her) **while** 4L followed by partner cast to dance Fig of 8 round 3L+2M & ends diagonally facing 3M (2s & 3s step up/down on bars 7-8)
- 9-16** 1s+4s dance 1/2 diagonal Alternating Tandem reel of 4 with 1st corners, 1s+4s pass LSh (1/2 turning other partner LH) & dance a 1/2 Alternating Tandem reel of 4 with 2nd corners & end passing LSh (1/2 turning other partner) & face 1st corners
- 17-24** 1s+4s repeat above reels, pass LSh & 1/2 turn other partner to end singly on opposite sides (from which they started) order 2 (1) 4 (3)
- 25-32** All dance 1/2 reels of 4 on sides, 1s+4s do not pass LSh but turn 2H to (3)(1) 4 2, all set & cross RH

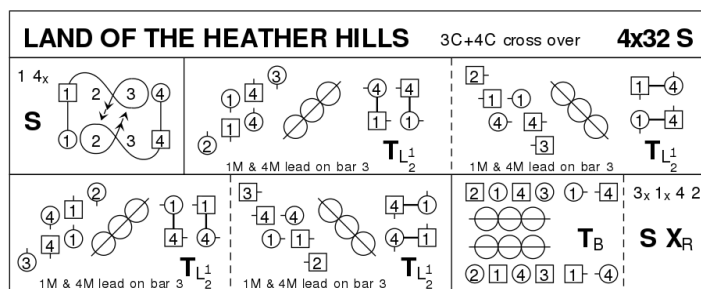

Barry Priddey, Capercaillie Book 2

4C/4C longwise set.

12 THE IRISH ROVER R32 · 3/4L

James B Cosh: *Twenty Two SCD · Crib: MiniCribs · Diagram: Keith Rose's Diagrams*

- 1-8** 1s dance down below 3s & cast up to 2nd place own sides, 1L dances RH across with 2s **while** 1M dances RH across with 3s
- 9-16** 1s dance 1/2 diagonal reel of 4 with 1st corners, 1/2 reel with 2nd corners & 1/2 turn LH in centre to face 1st corners
- 17-24** 1s dance reels of 3 across giving LSh to 1st corners ending in 2nd place own sides
- 25-32** 1s dance Diag R&L (1M crossing down & 1L crossing up to start)

